

5. RAINSCREEN SYSTEM

5.1. Introduction

In the context of envelope systems, the attention must be paid to buildings' energy and environmental issues; defining solutions that allow energy savings (Alagna, 2007), increase internal comfort conditions (Bazzocchi, 2002), easy to build, suitable for several contexts as well as durable. Compared to traditional models, these are systems that made the external envelope increasingly developed in a set of complex techniques, integrating architectural, structural, energy and systems features. Thus, the vertical closure becomes one of the most important technological elements in the design, to provide the best well-being conditions for the occupants in relation to functional peculiarities and its context. This happens because the vertical closure is the real filter between inside and outside, becoming the interface between systems that absorbs and releases heat, cools, changes air in the rooms and regulates natural lighting entry, etc.

On this regard, the main current interests are increasingly focused on the overall performance of the building, especially in reference to energy savings, including by means of automation processes, developing standardisation and prefabrication techniques of buildings construction and improving traditional products performance through new and environmentally friendly uses.

If we deal with only with the external wall component, despite the great variability of existing solutions, the different technologies that can be typologically classified refer to only two main approaches.

The first one is related to the testing and implementation of materials and related techniques belonging to tradition or an evolution of it, such as stone, ceramic, bricks but also composite, used with innovative methods. Otherwise, the second one is related to the use of metal and glass materials, particularly evolved and highly technological. However, there is a strong link in both contexts between the technical-constructive characteristics and those related to the energy operation of the envelope.

The naturally ventilated rainscreen façades technology belongs to the first category. They are widely used because of the benefits that they offer, not least the morphological flexibility, the variety of materials and cladding formats allowed. "*The rainscreen façade is a vertical closure that activates a rising air movement inside using radiant heat from the outside*" (Raffaellini, 1994; Baglioni & Gottfried, 1995).

This technology can be considered as an evolution of the more traditional external insulation and its applications are several nowadays (Lucchini, 1999). Despite being

the “simplest” of the so-called “advanced screen” technologies, they are the result of a complex design, particularly related to the thermo-dynamic behaviour of the façade.

There are many studies about the influence on buildings energy and environmental performance of using a ventilated façade. Gagliano et al. (Gagliano et al., 2020) demonstrate that the use of this technology lets saving energy from 20% to 55%, comparing it with a conventional unventilated façade in 2 representatives days of summer and winter seasons. Otherwise, some authors investigate the role and the influence of the type of the external cladding on the thermal behaviour of the ventilated façade and the energy performance of the building (Stazi et al., 2020; Fantucci et al., 2020). Other studies are concerned with the installation of a PV system on a forced ventilated façade and its integration with a heat pump to assess the benefits for a nZEB (Nearly Zero Energy Buildings) construction (García-Gáfaró, 2022). In this case, the decrease in heating consumption is about 21% for a residential building located in Spain.

5.2. Cladding Materials

External cladding is one of the most important formal components of the envelope, in relation to their materiality, colour but also format and size. Nowadays most façade claddings are developments of ancient materials, often combined with other very modern ones, that made their installation easier and improve their performance.

In the construction of complex façades (such as ventilated façades) these materials are used in an innovative way, even if they are derived from traditions such as natural materials. Since the technologies of the systems are contemporary, and generally mechanically dry installed. Moreover, the application methods are modern as well as the reduced thicknesses used. Furthermore, the design intentions of the author of the architectural work, who used traditional cladding materials on advanced screen façade or ventilated ones, often contrast with the non-load-bearing light façade. The latter is recognisable in the organisation of the fronts, size of openings, pattern of voids and solids on façade, creating formal effects hardly belong to historical constructive tradition (Gregorini, 1996).

There are many different cladding materials and the most used in complex facades are:

- natural stones and ceramics, typical of tradition, always used in wet-installation as construction materials for external facades and currently used in dry-installation solutions;
- bricks, which, certainly derive from the evolution of traditional construction techniques in their use with mixed wet/dry installation, and assume a more contemporary use in dry installation;
- large-format glazing, their use derives from the modern history of architecture;
- fibre cement, belonging to the most recent tradition of prefabrication;
- metal laminates, some are more common, others more recent and innovative;

- plastics, less commonly utilised but sometimes used as cladding for lightweight panels;
- composites, generally made up of inert materials and resins, provide a variety of aesthetic effects and are characterised by performances that natural materials could not have.

The main characteristics of some types of cladding are outlined below.

Stone Claddings

These natural materials have always been used in construction because of their considerable aesthetic value. They derive from the most classic building tradition (Blanco, 1993; Blanco, 1992).

Ornamental rocks can be grouped into 4 different categories, here classified according to commonly used commercial qualifications:

- “Marble”: it is a crystalline, compact, polishable rock, mainly made up of minerals with a Mohs hardness of 3 to 4. This category includes so-called marbles, i.e., recrystallised metamorphic limestones; calcifers and cipollines, limestones, dolomites and polishable calcareous breccias; alabasters; serpentinites; ophicalcites.
- “Granite”: it is a compact, polishable phanero-crystalline rock, predominantly composed of material of Mohs hardness 6 to 7, such as quartz, feldspars and feldspathoids. The granites proper (phanero-crystalline acid intrusive magmatic rocks consisting of quartz, sodic-potassium feldspars and micas); other intrusive magmatic rocks (diorites, granodiorites, syenites, gabbros, etc.); the corresponding effusive magmatic rocks with porphyritic structure; some rocks of similar composition such as gneiss and serizi, all belong to this category.
- “Travertine”: it is a sedimentary limestone rock of chemical deposit with a vacuolar structural characteristic, almost always polishable.
- “Stone”: this term refers to a category of rocks with a wide variety of mineralogical compositions. Normally they cannot be polished and can be divided into two basic groups: soft and/or not very compact rocks (calcarenes, sandstones with calcareous cement, etc.), and hard and/or compact rocks (micascist quartzites, lastroid gneisses, slates, etc. or volcanic rocks such as basalts, trachytes, leucitites, etc.). Nowadays, one of the main problems with these materials is determining their performance. This issue occurs particularly when they are applied with low thickness by mechanical fixing systems.

Considerable attention must be paid to the design of the system, from the substructure to the fixing systems, and to the joints, which must allow relative displacements between stone components. Absorption of elastic movements both between the substrate and cladding and the different slabs is generally resolved by the joints. In fact, they are the distancing of the perimeters of the different cladding slabs, with the aim of allowing free slabs displacements.

The closed joint installation scheme becomes an unaffordable solution because of the tendency to increasingly reduce the slabs thickness and the greater elasticity of the building structures. This type of technique is only recommended for claddings of limited size. In the case of a closed joint façade, the unavoidable settlements, elastic failures and differential thermal deformations between the cladding materials and the structure can result in slabs collapse and overloading the anchoring brackets and the cladding fixings. Moreover, this solution requires the joints to be left open at the floor slab. On the other hand, regarding the installation of medium-sized slabs, open joints ensure structural adjustments and displacements generated by thermal variations without contact between any of the adjacent elements.

To guarantee proper design, another very important feature to consider is the coordination and planning of construction tolerances.

Although high-tech façades are industrial products, they are inevitably linked to in-situ structures. Therefore, they require construction tolerances, especially in relation to the points of contact with the building load-bearing structure (Boeri, 1996).

Several UNI (Italian National Agency of Unification) standards define the classification of these materials, the methods to carry out the product acceptance or the control of the stone products characteristics, the rules to follow for proper technical information. Furthermore, the most important physical-mechanical characteristics for stone products identification and choice and the testing methods.

Ceramic Claddings

All products obtained by firing clays are included under the generic name of “ceramics”, in relation to the raw material purity, the relationship with appropriate additives, as well as the firing degree.

Historically, ceramics have been used as facade cladding with dry installation when formats of a significant size were made. Today it is precisely the large formats allowed and related contained weight, that made this product competitive, in relation to formal quality, performance and cost.

Ceramic materials can be divided into several types:

- porous paste products (earthenware, majolica, pottery), which can be painted, englobed or glazed;
- products with a compact paste, such as stoneware (ordinary or natural and fine or compound) and porcelain (hard and soft).

Finally, among the ceramic products that are difficult to classify, there is clinker. In its production clays are used and added with colouring oxides, fluxes and chamotte.

In the clinker production process, the rather high firing temperature (1200–1300°C) enables the achievement of “clinkerisation”, i.e., the vitrification of the mass. This property makes clinker one of the most resistant ceramic materials to aggressive agents.

Fine or composite porcelain stoneware is widely used in rainscreen facades. These differ from ordinary porcelain stoneware by clay greater purity and decrease in iron

oxides. Latter materials allow to obtain products with predetermined colours, even in paste form.

As far as ceramic materials requirements are concerned, they have very good mechanical resistance to compression and limited reliability to tensile strength. Ceramic materials have a marked degree of fragility. It increases as the firing temperature rises. In fact, ceramic elements of considerable size and small thickness are more easily subject to brittle fracture.

When using ceramic elements larger than 25 x 25 cm, special attention must be paid to the installation conditions. Particularly, the deformability of the tile support must be checked, i.e., thermal expansion and elastic deformation.

Imbibition property and permeability (dependent on porosity) are almost irrelevant in products with a compact paste, such as stoneware and porcelain, where the porosity must be less than 4%. Frostiness is inversely related to the degree of firing of the material and its waterproofness and compactness. However, it is always advisable to test for frost resistance the samples of ceramic materials used outdoors. The durability of ceramics is high in the case of dense body products, whereas in the case of porous body products, it is determined by frost and aging resistance. Regarding fire resistance, ceramic materials are generally more resistant than other materials, such as stone.

It is worth noticing that currently production of ceramic coverings offers on the market products with various treatments, including self-cleaning products (with a titanium dioxide coating) that give the material photocatalytic, super-hydrophilic and anti-bacterial properties. Other treatments can be mentioned, although generally not intended for façade applications, are silver-based, and give the material high anti-bacterial and anti-microbial properties.

The ceramic slabs can be fixed using either visible or not-visible fixing systems. With visible fixings, the slabs are supported by fixing clips of different types depending on the requirements to meet.

Clips must be fixed to allow for joints that permit possible expansion. The clips may be painted in colours like those of the ceramic slabs. In this case, they can be only slightly visible. Otherwise, if the design intention to leave them visible, they are not painted or coloured in a tint contrasting with that of the ceramic slabs. The vertical joint between the slabs generally varies from 4 to 8 mm, while the horizontal joint is approximately 8÷10 mm. Additionally, when the system is installed, applying a single-component silicone or polyurethane sealant to the slab-profile interface is advisable. Thus for 2 reasons:

- eliminating possible vibration of the slabs with wind;
- if breaking occurs, allowing slabs to be held until they are replaced.

To avoid slabs vibrations when exposed to wind action, an alternative solution is to insert a neoprene gasket in the aluminium profile of the substructure.

Ceramic tiles can also be fixed to the substructure by hidden fixings. In systems with concealed fixing made of dowels on the back of the slab and connected

with clips, the substructure can have both vertical and horizontal profiles. The distance between vertical ones does not depend on the module of the tiles, but on wind loads and building height. As regard the horizontal ones, the ceramic slabs are bound on them, and they will be at least 2 per slab. When the slabs are fastened using stainless steel dowels, thanks to their truncated-cone shape, they can be accommodated in the back of the slabs. Between the slab and the dowel there is a thin layer of neoprene. The drilling of the slabs is carried out in the factory. It is done using special tools that also create the undercut for the dowel as well. Once expanded, the dowel guarantees considerable resistance to tearing.

The cladding slabs are, then, fastened with shaped aluminium clips, normally 4 for each slab (2 load bearing and 2 containing). In this case it is worth noticing that the load-bearing clips are characterised by micrometric adjustment screw related to the fastening system to the transom.

For slabs thicker than 10.5 mm, an alternative not-visible fastening system, was made of mullions placed at each vertical joint. Mechanical stainless-steel support and restraint hooks are fixed to vertical profiles. Hooks are included into recesses made along the horizontal sides of the slabs.

To guarantee greater safety for the systems, it is advisable to glue a fibreglass mesh on the back of the tiles. It is generally a square mesh (4 x 4 or 5 x 5 mm), with an elastic adhesive (two-component polyurethane) that prevents fragments from falling off, in case of accidental tile breakage. This operation must necessarily be carried out on the portions of the façade located in the area where people pass by.

Brick Claddings

Brick is a traditional material that is currently subject of both product and process innovation. Additionally to traditional bricks production includes external cladding bricks with predominantly dry construction as well. Such as required for rainscreen facades. There is also a mixed “dry-wet” system. It enables to create external walls with a traditional design, but with technologies typical of drywall systems. The production also includes components for complex façades, such as variously shaped sunshades, slats, staves, squares, etc.

There are several products specifically dedicated to the complex facades’ construction, including: plates, panels, and tiles.

The terracotta plate is characterised by rectangular shape, and it is for instance 50 mm thick with through holes for lightening. The elements are obtained by drawing. The tiles can have shaped sides or continuous grooves (kerf) in both upper and lower sides. Slots are necessary to include load-bearing elements and two continuous sloping kerfs on the back. The latter are used in special cases where the plate is horizontal, such as in lintels or windowsills.

For façade installation, joints are generally approximately 6 mm wide both horizontally and vertically, with protection to prevent rainwater penetration.

Terracotta panels are obtained by a process of clay drawing too. They are flat elements, generally 25 mm thick with rounded or shaped edges. To give the panel greater

rigidity, they are characterised by a flaring at both lower and upper side. More stiffness is required when sides present holes needed to fasten to the substructure. This is a hidden and diffused type, as it is along the entire groove.

The substructure can be made of stainless steel or aluminium. When the substructure system includes mullions and transoms on the façade:

- the horizontal joints are created directly by positioning the support beam of the cladding element. Due to its special shape, it permits the required distance;
- the vertical ones are created simply by positioning the panels correctly on the transom, by sliding them.

The brick tiles developed from the typical horizontal elements used, for example, in the construction of floors. They are obtained by drawing from clay as well.

Longitudinally the voids through the elements have a lightening function and constitute an air chamber to the advantage of thermal resistance.

The special shape of both upper and lower edges allows mechanical fixings. When the substructure includes brackets (supported by mullions) to support and hold the cladding, they are usually made of stainless steel. Each bracket retains 2 both upper and lower sides and it is placed (on axis) at the intersection between horizontal and vertical joints resulting from the joining of the tiles. Generally, a small rubber element is applied at the steel-brick interface to ensure uniform transmission of stresses from the brick to the steel, avoiding stress peaks on the brick that has a brittle mechanical behaviour (Acocella, 2018).

Lightweight Multi-Layer Aluminium Panel Claddings

Multilayer, lightweight aluminium panels are often used in façade cladding, particularly in high-end manufacturing and tertiary construction.

Aluminium is characterised by its lightness, hardness, and good plasticity. Otherwise, it has a low mechanical resistance. This is improved by producing alloys with copper, zinc, silicon, magnesium, etc., that are characterised by a high resistance to atmospheric agents and particularly to corrosion.

There is a wide range of products. Considering as an example the best-known products, they consist of two aluminium sheets, including a mineral core.

The panels are manufactured in the factory using processes that allow cutting them to size.

The outer sheets are 0.5 mm thick while the inner ones are usually 2 to 5 mm thick, but can also be thicker. The panels do not undergo any surface corrugation or delamination and are particularly rigid and resistant to pressure and impact. If the size of the panels exceeds one square metre, especially in thinner thicknesses, it is advisable to apply to the back a stiffening element, such as a rigid insulation panel.

An important characteristic of this product is the possibility of being shaped, and therefore also folded on site. This allows a very wide range of applications, unrelated to large-scale mass production, making it particularly suitable for the usual façade cladding panels as well as for pillar cladding, roofing parapet one and corner elements.

The panel finishes are of various types: natural aluminium, pre-painted coil-coating, with natural and coloured anodising, PVC coating. The external side is pre-painted. There is also a very wide range of paint colours, both from the colour brochure and to order; they can also be metallised (Braicovich, 1998; Gottfried, 2003).

5.3. Façade System

There are now several types of high-tech technology façades, including naturally ventilated ones. They are one of the best systems for external building insulation.

The ventilated wall is rainscreen façade technology where all layers (including insulation one) are located outside the building load-bearing structure.

Thanks to the chimney effect created in the ventilation layer, during summer season the façade reduces the thermal flow entering the building and so decreases overheating inside the building. Otherwise, thanks to the external insulation, during winter season it keeps the internal surface temperature high. Additionally, the ventilation on the insulation external side eliminates possible condensation (Fig. 5.1) (Ciampi et al., 1998; Ibanez-Puy et al., 2017; Lin et al., 2022).

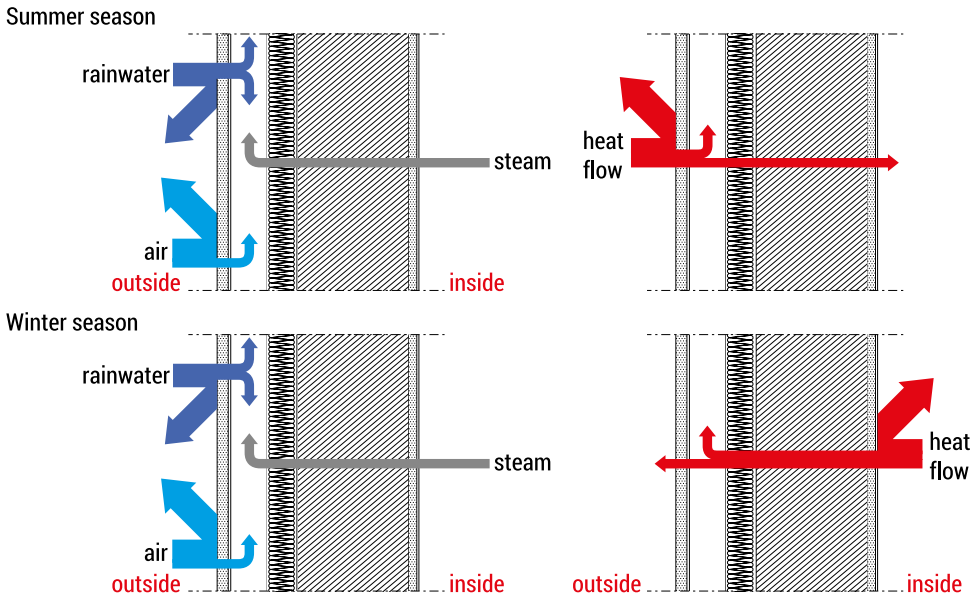

FIG. 5.1. Functioning diagram of a rainscreen façade in summer and winter season (Source: own elaboration)

From the load bearing layer, the ventilated façade stratigraphy is made of (inside-outside): an insulation system, with thermal insulation directly applied on the external wall (i.e., its external side), an open-air cavity and, finally, the outer face, i.e.,

the covering layer. In the air layer an air rising movement is triggered (chimney effect) permitted by appropriately positioned openings protected by grids.

The possibility of natural ventilation must be ensured through the correct sizing of the ventilation openings. These are generally located at both the lower and upper ends of the external cladding, and at suitable heights to ensure the chimney effect.

The ventilated wall is a non-load-bearing wall, and the cladding have its own supporting structure, called substructure. It is supported and constrained to the main structure of the building and the load-bearing layer of the wall.

The substructure is made of several components. These elements are fixed to the load-bearing wall layer and support the cladding. The covering will be offset by at least 17÷18 cm from the external side of the structure.

The ventilated wall is made up of the following layers (Ciampi, 2007). They are outlined in succession starting from the structural side to the outside.

Load-Bearing Layer

The load-bearing layer must carry the loads of the ventilated wall system. This occurs when it is not directly connected to the building load-bearing structure. Today, thanks to the great variety of available components on the market, the ventilated wall system can be installed on any type of support, using appropriate elements. The system required that the supporting structure must be characterised by flatness, verticality, and horizontality. The ventilated façade system should be applied to buildings with a certain geometric regularity, characterised by a ratio between full and empty spaces to allow “ventilation chambers” correctly functioning.

The load bearing layer can be either a structural element, a wall or both. It must necessarily be statically verified since it represents the load-bearing element for the whole system.

The load bearing layer can be:

- non-continuous if the building structure is a reinforced concrete or steel frame. Therefore, it will have non-load-bearing external vertical walls;
- continuous if the building structure is a load-bearing masonry, variously built (traditional brick masonry, small elements, and blocks), or with reinforced concrete diaphragm.

In the first case, the anchorage of the mechanical devices supporting the substructure is directly on the framed load-bearing structure, and the so-called system retrofit fixings can be anchored on the walls. However, in the second case, the positions of the substructure supporting fixings will not be determined by the structural frames' modularity.

Regularization Layer

A levelling layer may be applied on the outside of the load bearing layer. Generally, if the resistant layer is a masonry, it consists of a cement mortar plaster (2 cm thick) to make the surface regular and coplanar to apply then the insulation material.

The regularization layer is used in both the case of non-continuous load-bearing support (walls), or continuous one except in the case of reinforced concrete diaphragm. Before positioning the insulation layer, it is important to check the condition of the substrate surface and to assess any possible geometric irregularities to correctly apply it.

Insulation Layer

This is the insulating layer, placed uniformly, either close to the load-bearing layer or of regularisation one (when present). This application is the “coat” of the building, with the aim at improving the thermal insulation and minimising possible thermal bridges.

It must be chosen appropriately because it must necessarily be:

- with low thermal transmittance value;
- hydrophobic;
- fire resistant so it avoids flame propagation during possible fire event;
- non-perishable and non-alterable;
- self-supporting and with sufficient mechanical resistance.

Although there are several products available on market, generally mineral or vegetable fibres as well as cellular plastic rigid insulating panels are used in rainscreen systems to meet performance requirements. They are suitably sized according to the overall energy performance of the wall and applied directly on it.

They are installed using mechanical elements consisting of fasteners (usually plastic with top as a disc) and adhesives, or both.

Insulation materials can be:

- inorganic or mineral origin (e.g., mineral fibre insulation, glass foam, perlite sheets and slabs, vermiculite);
- organic origin, derived by synthetic raw materials (e.g., polystyrene rigid foam, expanded polystyrene particle foam, extruded polystyrene rigid foam, polyurethane rigid foam, formaldehyde-based foam, phenolic resin-based rigid foam) or by natural ones (e.g., cotton, linen, hemp, wood fibre, coconut fibre, cork, sheep wool, reed, cellulose fibre).

Ventilation Layer

In naturally ventilated facades, the ventilation layer consists of an air chamber connected to the outside environment. It is located between the insulation layer and the cladding of the wall and functions like a natural convection chimney. The ventilation is external-external type, i.e., it is not connected with either the interior rooms or the building’s system.

The fundamental role of the cavity is to enhance the thermal comfort and more generally to achieve well-being conditions inside the building (Gagliano et al., 2022). The air convective motion activated allows: the evacuation of water vapour coming from inside, allows the elimination of the negative effects caused by any water

penetration and the control of interstitial condensation. The latter permit to reduce the possibility of condensation phenomena that could lead to the deterioration of the materials.

During summer, ventilation contributes to a significant decrease in heat flux into the building. While in winter season, it has a positive effect on condensation and frost formation, but it does not ensure any thermal benefits in terms of controlling energy losses. There would be advantages if the ventilation chamber could be closed because this would increase the overall thermal insulation of the wall.

This opportunity would become feasible by providing a manual or automatic control system for opening/closing the ventilation openings. Even in this case the ventilation cavity would not be airtight since in almost all cases the joint between the cladding elements is open. If the air cavity would be closed surely some of system benefits would be lost.

The operation of the ventilation chamber is closely related to the environmental boundary conditions, the building morphology, and the wall composition. To activate a real chimney effect, the air gap must have an adequate section (at least 6 cm) without any obstacles inside (for instance the substructure components can cause turbulence phenomena).

For effective ventilation the air cavity must have a constant thickness between the air inlet and outlet openings, maintaining a regular and continuous configuration. During the design of the system, all possible causes that could influence the smooth circulation of air have to be considered. For instance, elements (generally horizontal) interrupting the verticality of the air layer must be avoided because they could trigger local turbulence effects and interfere with the main upward air movement.

The sub-division of the ventilation chamber is often unavoidable. On this regard, the proper functioning of all the different parts must be verified. In the design phase all the various ways in which ventilation happens in the façade are necessarily evaluated. Unlikely it is uniform, varying according to the building morphology and size of the, the façade technology chosen and the specific orientation and exposure of the building. All those parameters will affect the operation of the ventilation chimneys.

Ventilation openings are usually located at both the bottom and the top of the air ventilation layer. They are protected by gratings to limit the entry of insects and other small animals, and by flashings to avoid rainwater entry. The openings must be necessarily positioned whenever the ventilation chamber is interrupted, for instance by the presence of windows.

The design of the shape, size and positioning of the ventilation openings in the façade is also important. This because they make a key contribution to the correct functioning of the ventilation “chimneys”. Generally, the size of the ventilation openings must be at least 70÷80 % of the ventilation chamber section. The type of protection system for the openings is another aspect to consider. It must not obstruct or divert the flow of air in an uncontrolled way (Fig. 5.2).

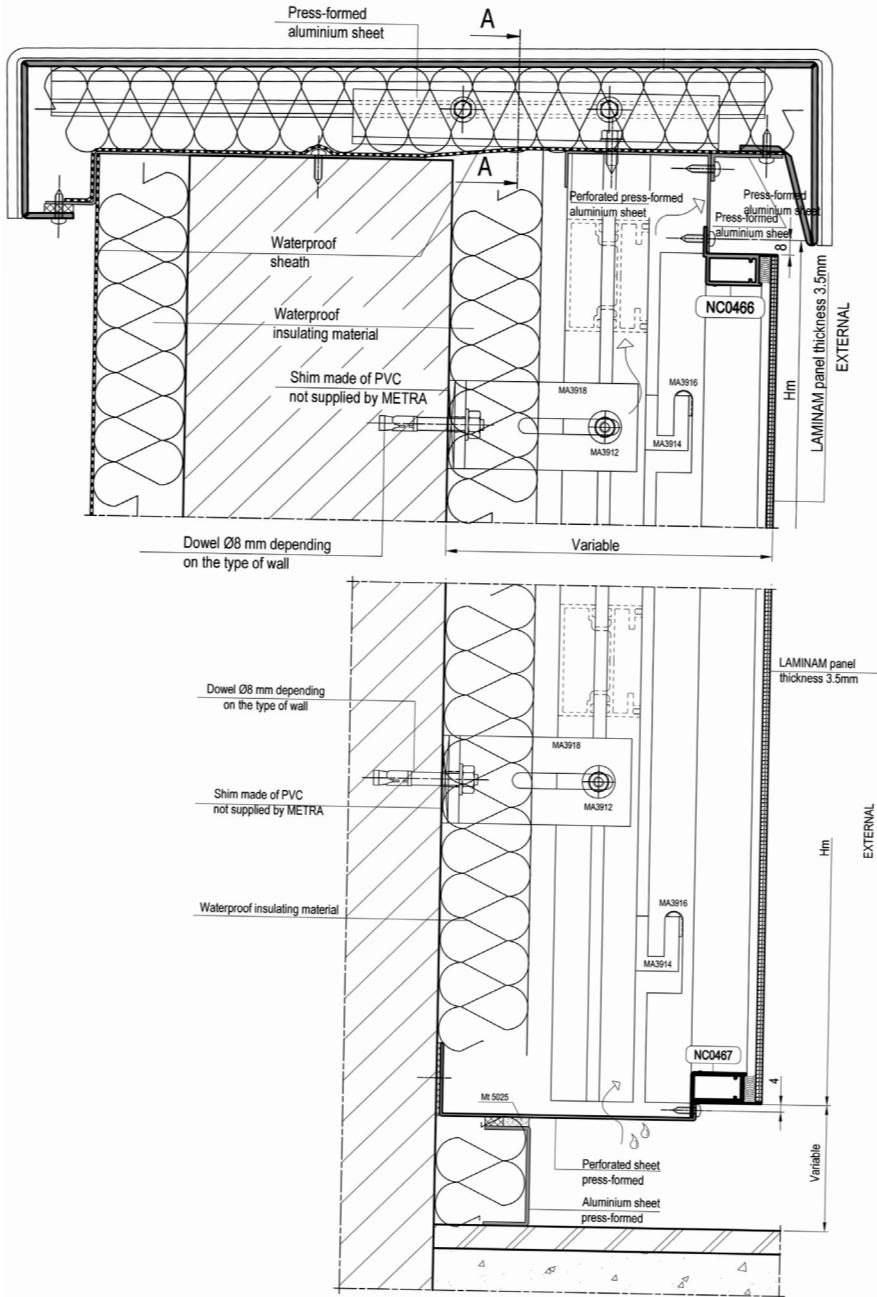

FIG. 5.2. Example of a vertical section of a rainscreen façade showing ventilation openings at both the top and bottom (Source: The technical material in question is the property of METRA Spa)

Substructure System

Substructures are very important. They are anchored to the building load-bearing structure and enable the anchoring of the cladding fixing systems. Metal components must be used to support and fix the ventilated facades. These elements are anchored to the building external structure, and they are the façade supporting structures involving dry fitting for the individual components.

The substructures enable the cladding elements to be supported or retained through fixing devices such as pins, plates, inserts, etc. They are accommodated in special holes, grooves, or slots in the cladding.

The design of this system depends on the load conditions, the thermal actions, the differential displacements of the structures, but mainly on the properties of the cladding, the format of the elements as well as the aesthetic-formal features to be obtained.

A substructure could mean a simple component (such as a bracket), but it is generally made up of a set of components (such as a mesh made up of welded and/or bolted vertical and horizontal profiles). The assembly of these elements constitutes the support for the external cladding as well as suitably distancing it from the insulating layer to create the ventilation chamber.

Nowadays the materials used for both the substructures and the cladding fastening systems are metals, in particular stainless steel, galvanised steel, and aluminium. The design and assembly of the substructure must always consider the principles of statics to guarantee safety and correct deformation under the action of both horizontal (wind and earthquake) and vertical loads (weight of the structure and of the cladding).

The quantity and size of the support elements will be determined in each individual case based on the specific stresses. Supporting components are usually fixed with dowels to the load bearing layer and equipped with vertical and horizontal adjustment.

Basically, the choice of system will depend on the type of cladding element to use on the façade and more specifically on the choice of the type of fixing of the cladding element to the substructure (Fig. 5.4).

To clarify the relationships between the elements, the diagram in Figure 5.3 is used.

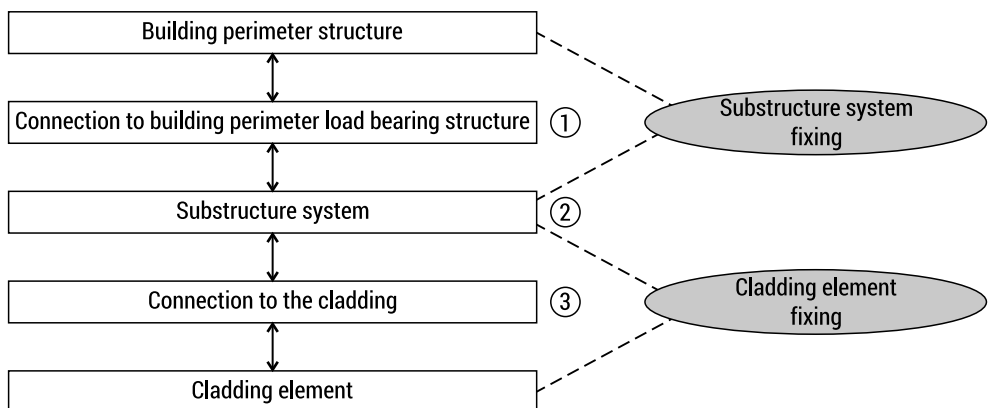

FIG. 5.3. Connections between different layers (Source: own elaboration)

Methods for classifying substructures may be various and the used one attributes a fundamental role to the cladding fixing type. The multiple characteristics of anchors allow the proper application of the same fixing to several different materials and types.

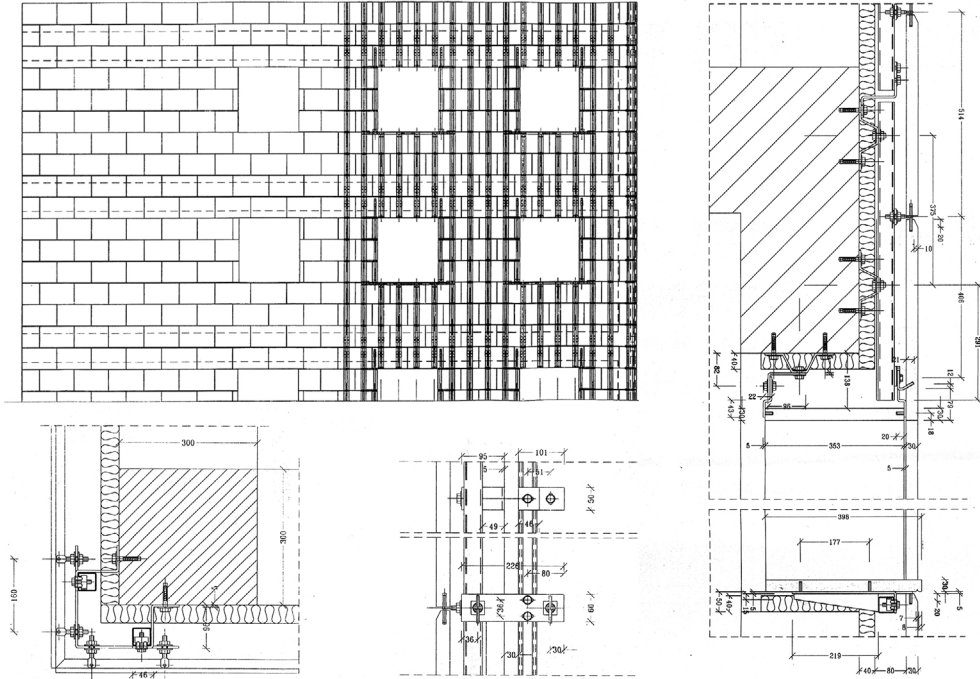

FIG. 5.4. Example of a rainscreen façade with a mullion substructure and cladding fixing with pegs (Source: own elaboration based on Senesi & Maronaro)

The following Table 5.1 shows for each materials macro-categories the possible type of fixing system.

TABLE 5.1. Possible cladding fixings (Source: own elaboration)

Material type	Possible type of cladding fixing	
	Point fixing system	Distributed system
Stone	Pegs in holes, brackets in grooves on edges.	Continuous profile within grooves on edges.
	Dowels on the back.	
Ceramics and composite	Pegs in holes, brackets in grooves on edges.	Continuous profile within grooves on edges.
	Edge clips.	
	Dowels on back.	
	Brackets within grooves on back.	

Material type	Possible type of cladding fixing	
	Point fixing system	Distributed system
Brick	Dowels on back Pegs/Brackets on edges.	Continuous profile within grooves on edges.
	Dowels on back.	Support brackets.
Metal alloys	Point fixing through Grips offered by the coating.	Grips offered by the cladding.
Lightweight panles	Dowels on back.	
	Grips offered by the coating.	

Connections to the Cladding

Cladding fasteners (mainly mechanical connections but also chemical-mechanical one) can be divided into two groups.

The most used type is point fixing systems. In this case, the fastening is carried out by a sufficient minimum number of anchorages of the cladding, so the system is isostatic (also called “safe life”). When using these systems, measures must be taken to limit damage in the event of a collapse of the cladding. The materials used today for these couplings are stainless steel (AISI 304 and 316), or treated with anti-corrosive procedures, and aluminium alloy.

The second type is the diffuse fixing systems, built by anchorage components that constrain the cladding in a diffuse manner, obtaining a hyperstatic type system (also called “fail safe”). In case of failure of a cladding element this connection system limits its total collapse.

Connections' type can be distinguished between hidden cladding fastening systems, (i.e., those with components that are not visible when the façade is completed) and exposed ones (the cladding fastening component is visible or partially visible). *Visible fastening systems* are exclusively of the point fixing type. If there are 4 fasteners per cladding slab, two have the function of carrying it and the others must retain it in relation to the depression caused by the wind.

Concealed fastening systems can be either point systems or diffused ones; the former generally include special dowels accommodate in non-passing holes made on the slabs back; the latter, generally used for stone materials, include continuous plate accommodate in a continuous groove on the slab edge.

Point fixing systems include components that constrain the covering as follows.

- *Pegs inserted into holes in the cladding slab edge*: depending on requirements, these holes and the resulting pegs can be applied both on the horizontal edges (top and bottom) of the slabs and on the vertical ones (Fig. 5.5). Pegs (made of AISI 304 stainless steel) are installed on holes made on the slab edges. This type of delicate connection requires great precision both when drilling the holes on the cladding edges and during installation. Before inserting the pegs, an elastic tube made of nylon, or another plastic material, is accommodated in the holes to prevent direct contact between peg and cladding. The holes

on the bottom should be filled with mastic to prevent either any stagnation of rain-water that could stain or deteriorate the material as well as create dangerous situations of frost that could cause the cladding to break.

- *Brackets inserted into grooves on the cladding edges:* the brackets are inserted into suitable size grooves on the horizontal edges of the cladding by milling, to produce carvings, also known as “kerfs”. This type of processing allows greater flexibility during construction. In some cases, the kerfs are also combined with pegs, resulting in a mixed fixing on the same slab.

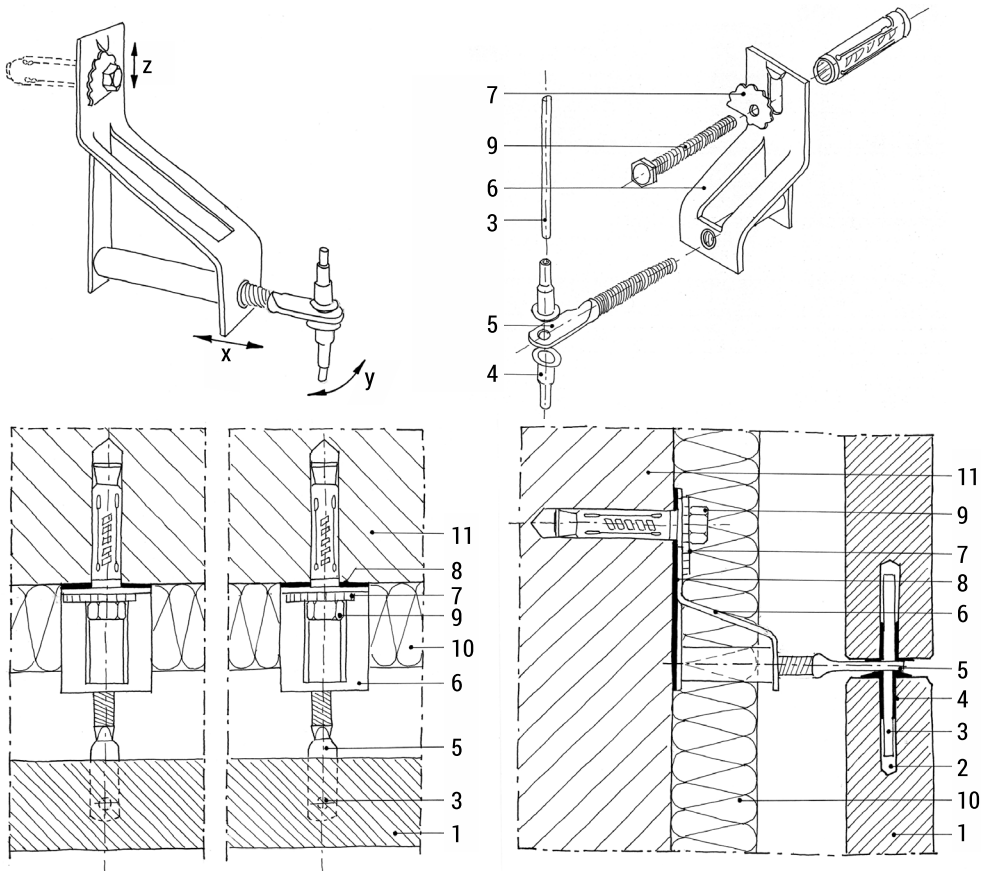

FIG. 5.5. Point fixing system with pegs in holes in the cladding edge. Caption: 1. Cladding; 2. Peg accommodation; 3. Peg; 4. Nylon tube; 5. Adjustment screw; 6. Fixing bracket; 7. Adjustment washer; 8. Bracket thermal break; 9. Expansion anchor; 10. Insulation panel; 11. Load bearing layer (Source: own elaboration)

- *Clips or brackets in grooves or recesses on the cladding slab back:* this fixing is carried out by shaped stainless-steel clips or brackets that fit into suitable size and oriented grooves (slots) milled into the back of the cladding. The substructure is usually made of extruded aluminium (Fig. 5.6).

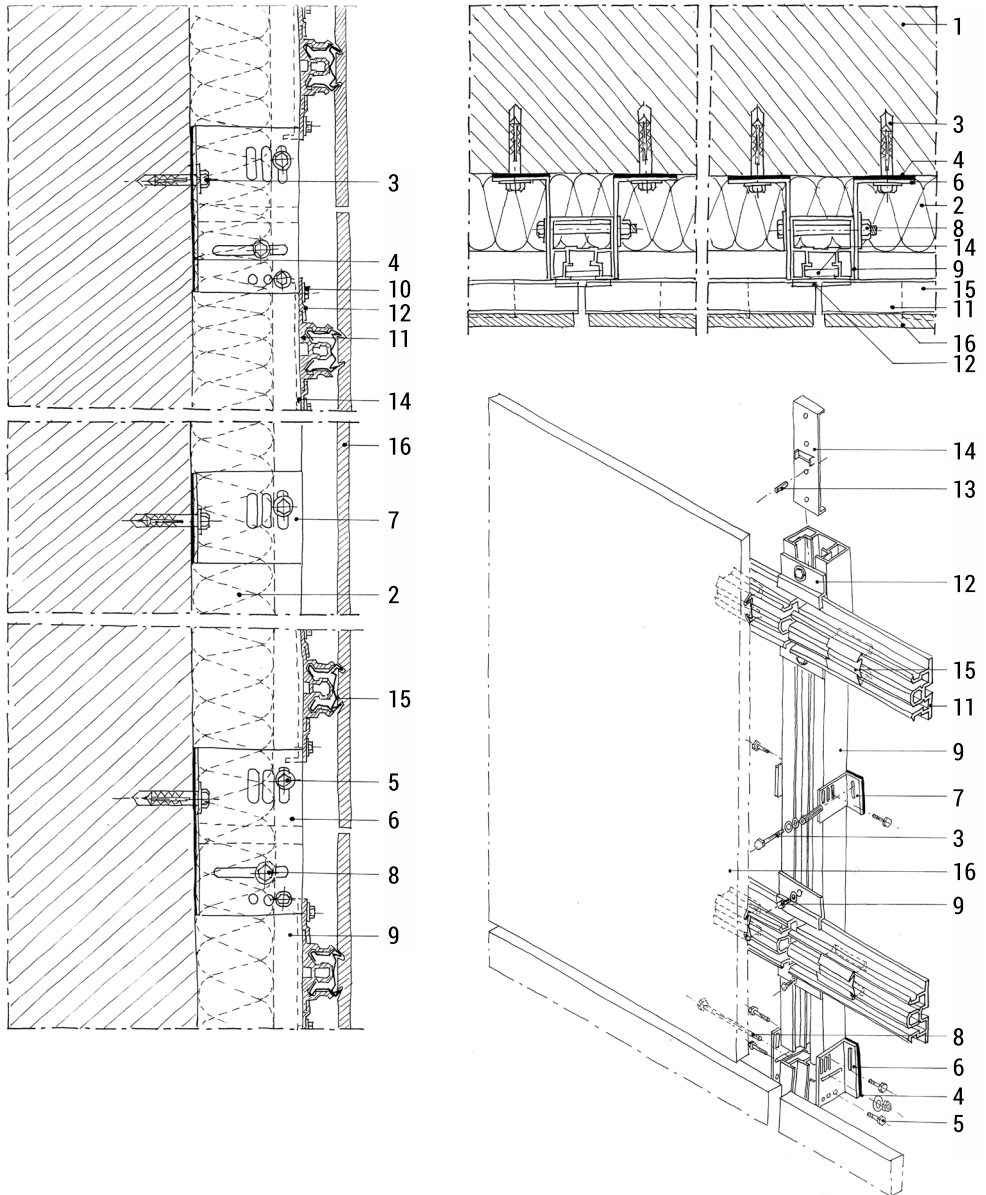

FIG. 5.6. Point fixing system with brackets in grooves on the back of the cladding, with mullions and transoms. Caption: 1. Load bearing layer; 2. Insulation panel; 3. Expansion anchor; 4. Bracket thermal break; 5. Self-tapping screws; 6. Main fixing bracket; 7. Secondary fixing bracket; 8. Bracket clamping screw; 9. Aluminium mullion; 10. Screw for fixing the little bracket to the slider node; 11. Aluminium transom; 12. Little bracket; 13. Set screw; 14. Slider node; 15. Snap-on fixing clips; 16. Cladding (Source: own elaboration)

- *Dowels on slab back*: this type of fixing consists of dry fitting metal inserts, generally involves of concealed threaded pins or bushings, on the back of the slab in fixed positions, connected to the substructure. This system may include self-locking threaded male/female bushes in austenitic stainless steel on the back of the slabs (they could be thinner). This mechanical locking system is not visible and has a certain variety of products (even without protrusions on the back of the slab).
- *Clips on the edge*: this type of fixing is achieved by steel or aluminium clips which support the cladding on the lower side and hold it on the upper one. This type of fixing is visible because part of the clip is also visible on the cladding outer face. This type of fixing does not require any machining of the cladding slabs.
- *Shaped brackets on the cladding edges*: this hidden fixing is carried out by shaped plates. They fit to the cladding element profile and support or retain it punctually. The edge of the cladding (generally made of brick) is shaped during the production phase to hide the fixing system as well as to perfectly fit the brackets.
- *Grips provided by the cladding*: thanks to the shape, in this case the cladding elements create grooves for their own attachment to the substructure and are hung on it. This is only possible for certain materials (aluminium) or components (lightweight boards) where the production process allows to shape them in such a manner that they can be fixed to the substructure in this way.
- *Point through-hole fastening*: This type of fastening connects the cladding to the substructure by self-tapping screws or rivets, passing directly through the cladding element edges. They are used with aluminium substructures and for lightweight claddings such as metal alloy panels. In the case of heavy cladding, steel dowels are used with a steel substructure (Fig. 5.7, Fig. 5.8).

The following types belong to the distributed fixing systems.

- *Continuous profile within grooves on edges*: the groove (kerf), that accommodates the profile, is obtained by milling or forming over the entire width of the horizontal slab edges. In this case the cladding element must be thick enough to allow fixing without the sides becoming fragile.
- *Support brackets*: made of steel, they are usually associated with ventilated façade with a heavy external finishing made of brick.
- *Grips provided by the cladding*: in this case the cladding is fixed by fastening the suitably shaped horizontal edges of the cladding panels. This is a typical system of metal alloy cladding.

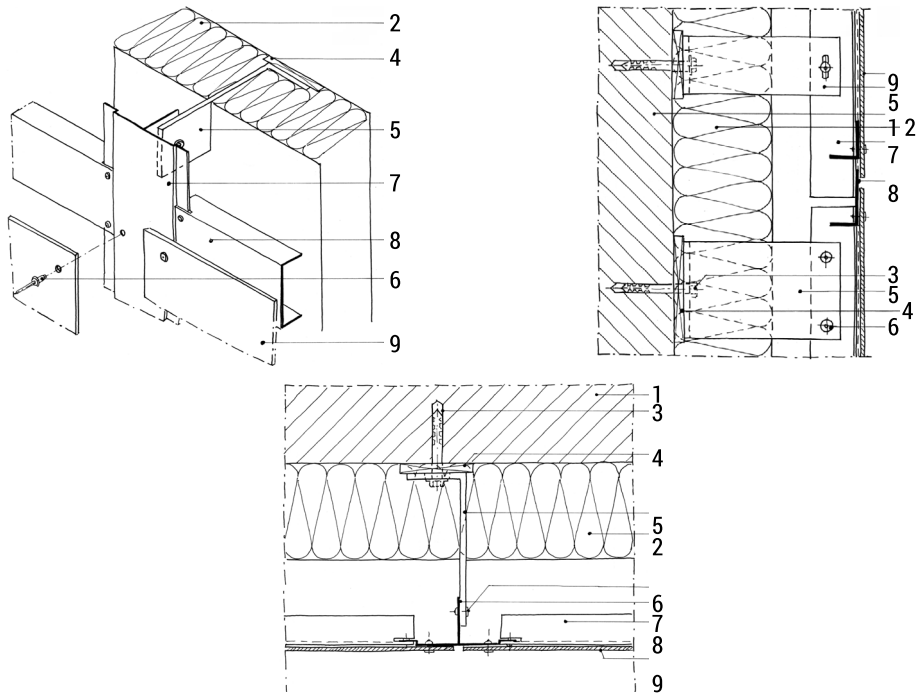

FIG. 5.7. Point fixing system through the cladding, with mullions and transoms. Key: 1. Load bearing layer; 2. Insulation panel; 3. Expansion anchor; 4. Bracket thermal break; 5. Fixing bracket; 6. Rivet; 7. T-shaped aluminium mullion; 8. U-shaped aluminium transom; 9. Cladding (Source: own elaboration)



FIG. 5.8. Point fixing system through the cladding, with mullions. Backhaus Mahl, Albstadt-Tailfingen – Germany (Source: © Courtesy of Alucobond, © Elisabeth Leblanc)

Supporting Structure

Through a profiles mesh, the structural frames supporting the cladding fasteners allow the transfer of all the stresses (inherent and induced) to the load bearing layer by proper fastenings. The mesh may consist of metal profiles (stainless steel, aluminium, or less recommended galvanised carbon steel) arranged to identify a main and a secondary frame. In general, the vertical development prevails (mullions), since all the connections to the load-bearing structures of the building can easily be made. Particularly in the case of framed structures because it is easy to fix them to the slabs' side beams. Often, a secondary system is connected to the main frame, made with metal profiles warped in the opposite direction (transoms). In other cases, the wall is built exclusively with stringers or brackets, directly anchored to the necessarily continuous load-bearing structure.

System components are also used to correct any out-of-plumbness: usually shims are applied between the substructure and the fixing system to the main structure and/or between the substructure and the fixing system of the cladding. Generally, the elements are connected to each other oval-shaped slots to allow installation tolerances and differential displacements. It is worth to notice that the most used mullion and transom sub-structures may sometimes have the disadvantage of avoiding (through transom) the air ascensional movement in the ventilation layer. Consequently, a carefully evaluation of the operation of the ventilated cavity is required. Obviously, if there are real functional deficits and the same system must be kept, the use of fixing devices to distance transoms is needed to increase the cross-section of the ventilation cavity.

It should also be noted that since the substructure system is almost entirely made of metal, it must be connected to an earthing system.

The substructures may be

- *mullions (or transoms)*: in this system, the façade modules have straight vertical joints, while the horizontal ones may be staggered. On the other hand, in the case of transoms the horizontal joints are straight, while the vertical joints may be staggered.
- *mullions and transoms (or transoms and mullions)*: this system allows the widest possible modularity of the cladding. It may have straight vertical joints, straight horizontal joints, staggered joints, or continuous joints; this is because the cladding panels geometry is independent by the vertical sub-frame.
- *with brackets directly fixed to the main continuous structural support*: in this case the position of the brackets obviously will be decisively connected to the geometry of the modular mesh of the facade cladding.

Finally, the substructures must be constrained to the building by a suitable fastening system:

- *mechanical anchors*, made of galvanised or stainless steel: these have excellent resistance to sliding and maintain their sealing capacity almost unchanged, even in partial initial slipping event. There is a wide range of dowels on the market, suitable for all load requirements and all types of load bearing layer.

- *chemical anchors*, external or internal mixing type and particularly suitable for use on non-compact fixing bases.
- *profiles embedded in the casting during the construction of the load bearing structure*, made of normal and stainless steel, heat-rolled or cold-formed, with pressed or welded anchors. They are usually C-shaped, allowing the insertion of the bolts needed to fix the other ventilated façade elements. They are supplied by the manufacturers with a foam filler to prevent concrete enters during casting.
- *Bolted joints in the case of structural steel frames*: these must be suitably designed to cope the tensile and especially shear stresses caused by the loads resulting from the substructure and the external cladding.

Joins System

The joint is the space between the perimeter of each cladding element with the aim at allowing free movement due to differential displacement. Additionally, to a precise functional connotation, this element determines and characterises the façade aesthetics, highlighting its modularity. The rarely solution of the closed joint requires a gap of about 2÷3 mm between the cladding elements. In these cases, it is advisable to leave the corresponding joints with the slab open of about 15÷20 mm. Open joints allow greater displacement of the cladding elements, and generally of 6÷7 mm. This system, which is the most widely used, allows to accommodate medium-large slabs without any contact between them during settlements and movements caused by thermal expansion.

References

- [1] Acocella, A. (2018) *Involucri in cotto. Sistemi innovative per il rivestimento in architettura*, Firenze, Sannini Impruneta.
- [2] Alagna, A. (2007) *Tecnologie per le forme dell'architettura contemporanea. I sistemi di chiusura: qualità ed efficienza energetica*, Firenze, Alinea. ISBN: 978-88-6055-137-5.
- [3] Baglioni, A., Gottfried, A. (1995) *Manuale di progettazione edilizia. Vol. 4*, Milano, Hoepli.
- [4] Bazzocchi, F. (a cura di) (2002) *Facciate ventilate. Architettura, prestazioni e tecnologia*. Firenze, Alinea.
- [5] Blanco, G. (1992) *Pavimenti e rivestimenti lapidei*, Roma, Ed. NIS.
- [6] Blanco, G. (1993) *Le pietre ornamentali in architettura*, Roma, Ed. NIS.
- [7] Boeri, A. (1996) *Pietre naturali nelle costruzioni: requisiti, criteri progettuali, applicazioni e prestazioni*, Milano, HOEPLI.
- [8] Braicovich, E. (1998) *L'architetto e l'alluminio. Nuova finestra*.
- [9] Ciampi, M., Tuoni, G. (1998) *Sul comportamento delle pareti ventilate in re-gime periodico. La Termotecnica*, 11.
- [10] Fantucci, S., Serra, V., Carbonaro, C. (2020) *An experimental sensitivity analysis on the summer thermal performance of an Opaque Ventilated Façade. Energy and Buildings*, 225, 110354.
- [11] Gagliano, A., Aneli, S. (2020) *Analysis of the energy performance of an Opaque Ventilated Façade under winter and summer weather conditions. Solar Energy*, 205, 531-544.

- [12] García-Gáfaró, C., Escudero-Revilla, C., Flores-Abascal, I., Erkoreka-Gonzales, A. (2022) A photovoltaic forced ventilated façade (PV-FVF) as heat source for a heat pump: Assessing its energetical profit in nZEB buildings. *Energy and Buildings*, 261, 111979.
- [13] Gottfried, A. (2003) I rivestimenti, Milano, HOEPLI. ISBN: 9788820331498.
- [14] Ibanez-Puy, M., Vidaurre-Arbizu, M., S. Fernandez, J.A., M. Gomez, C. (2017) Opaque ventilated faacdes: thermal and energy performance review. *Renewable and Sustainable Energy Reviews*, 79, 180-191.
- [15] Lin, Z., Song, Y., Chu, Y. (2022) An experimental study of the summer and winter thermal performance of an opaque ventilated façade in cold zone of China. *Building and Environment*, 218, 109108.
- [16] Lucchini, A. (1999) Pareti ventilate, Bologna, SAIE.
- [17] Raffaellini, G. (1994) Manuale di progettazione edilizia. Vol. 2, Milano, Hoepli.
- [18] Stazi, S., Ulpiani, G., Pergolini, M., Di Perna, C. (2020) The role of wall layers properties on the thermal performance of ventilated façades: Experimental investigation of narrow-cavity design. *Energy and Buildings*, 209, 109622.
- [19] WEB-1: Ciampi, A. (2007) Facciate ventilate in cotto. [Online] Available from: <https://www.arketipomagazine.it/facciate-ventilate-in-cotto/> [Accessed on 21.03.2022].