

7. COGENERATION SYSTEMS

7.1. Introduction

In the 2012/27 Directive of European Parliament (DIR 2012/27 EU, 2012) and Council on energy efficiency is stated that: „<...> high capacity cogeneration units should be installed in order to utilize waste heat generated by producing electric energy. Subsequently, this waste heat could be transferred by district heating networks where it's needed. <...> high-efficiency cogeneration should be defined as an amount of energy, which is saved instead of separate production of heat and power in pursuance of co-production”.

The directive contains some definitions:

- *Energy efficiency* – the ratio of the created work, services, received goods, energy and energy consumption;
- *Cogeneration* – simultaneously ongoing production of heat and electric or mechanical energy;
- *Utility heat* – heat generated during cogeneration, which is economically purposed for satisfaction of heating and cooling demand;
- *Cogeneration unit* – unit, capable of operating in cogeneration mode;
- *Low power cogeneration unit* – a cogeneration unit with less than 1 MW_e installed capacity.

Cogeneration technologies listed in this directory are:

1. combined cycle gas turbine with heat usage,
2. pre-pressured gas turbine,
3. condensing steam evaporation turbine,
4. gas turbine with heat usage,
5. internal combustion engine,
6. microturbines,
7. Stirling's engines,
8. fuel elements,
9. steam engines,
10. organic Renkin cycles,
11. other types of technologies.

Regarding power and purpose cogeneration, power plants are distributed as follows:

- *High Capacity* (>50 MW) urban cogenerational power plants (high effectiveness cogeneration), which produce electric energy and heat. Heat is supplied to the users of district heating.
- *Medium Capacity* (from 1 MW to 50 MW) urban cogenerational power plants, which produce electric energy and supplies heat to local heat transfer networks.
- Building cogeneration power plants, which produce electric energy and supplies for building/ buildings group needs of heat.
- Industrial cogeneration power plants, which produce electric energy and steam or hot technological water for needs of industrial companies.

Currently, steam turbines, gas turbines, combined cycle engines and internal combustion (piston) engines are the most common in the world.

Cogeneration can be defined as the general production of thermodynamic heat and electricity from a single initial source of energy. The device, in which the process of cogeneration occurs, is called cogeneration device. Cogeneration changes separated electric energy and heat production. The separation of electric energy and heat production is characterized by substantial energy losses of initial fuel. In the separated power generation, the user receives the electric energy, which is produced by the large-scale power plants and heat is produced in high-efficiency boilers. In this case losses make about 40% in produced heat and 60% – produced electric energy.

Figs. 7.1 and 7.2 show losses, when separate thermal and electric energy is produced (boiler house):

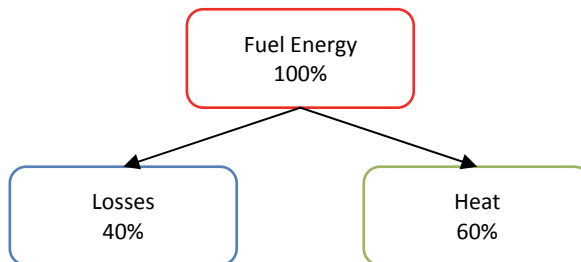

Fig. 7.1. Boiler House (Source: own elaboration)

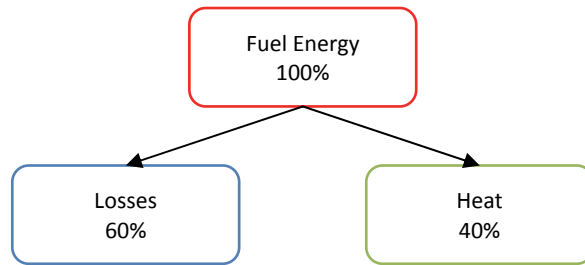

Fig. 7.2. Condensing Plant (Source: own elaboration)

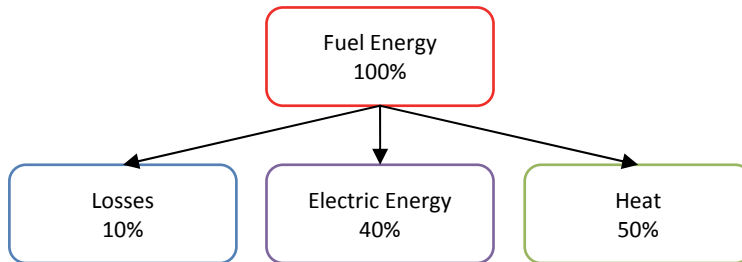

Fig. 7.3. Cogeneration Device (Source: own elaboration)

Electric energy is produced by hydroelectric, thermal and nuclear power plants. About 75% of the thermal energy is centralized and supplied to the heat consumers from thermal power plants and boiler houses. This centralized production and provision of electricity and heat reduces the expenditure of consumption, reducing the quantities of contaminants into the atmosphere.

With increasing prices of fuel and declining resources of fossil fuel, attention is paid to the new development of electric energy and heat production equipment (CHP plant) and the usage of renewable resources of energy.

7.2. Steam turbines

Steam turbines are the most commonly used cogeneration units. The working principle of steam turbine is based upon the expansion of steam inside the turbine. Superheated high-pressured steam is generated in energy boilers, which generates mechanical energy by expanding in the steam turbine, used to generate electric energy in a generator. When small and medium pressure cogeneration steam turbines are used, only 7-20% of fuel energy is converted into electric energy. A large portion

of energy is converted to heat (steam). The power of the steam turbine ranges from 500 kW to 500 MW.

The steam turbine transforms water vapor heat energy into mechanical energy. Steam turbines are divided into *active* and *reactive*. In active turbine, the potential energy of water steam is transformed into kinetic energy used in installations for fixed nozzles and useful creation of work for turbine blades. The first active gas turbine was constructed by a Swedish engineer, Laval in 1889 (Fig. 7.4).

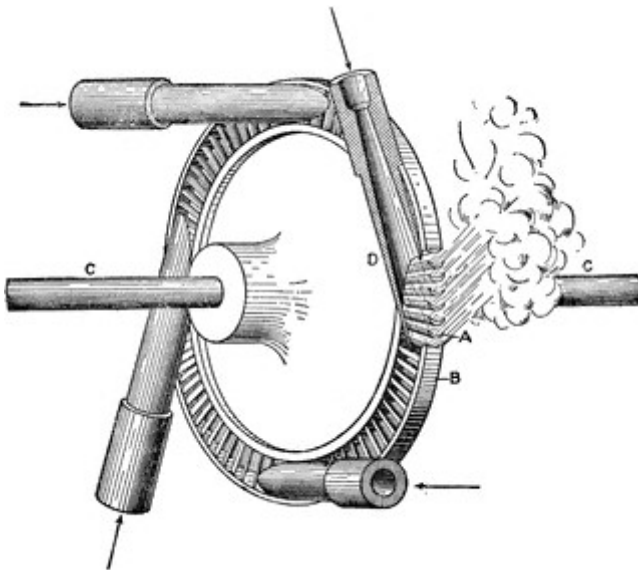

Fig. 7.4. Laval's Steam Turbine (Source: WEB-1)

Laval's Turbine – is gyro fitted with blades. Steam flow, outflowed from the stator's nozzles, presses the blades and turns the gyro (the rotor).

Reactive turbine indicates that the part of water vapor's potential energy is converted into mechanical work of the rotor – impeller, which has the configuration of reactive nozzle, in the channels of blades. Reactive turbine was invented by English engineer Ch. Parsons in 1884. Each guiding and working blade's turn is called the *turbine's degree*. In one-degree turbine steam, energy is not insufficiently exploited, so modern turbines are built to be multi-level. When steam passes through a number of blades, it gradually expands and its kinetic energy is converted into kinetic energy of the rotor rotation. The longer the pallets of the rotor are, (wherewith pressure is lower, longer are the pallets of the rotor) the lower the pressure. The steam produced in the turbine is directed to the condenser.

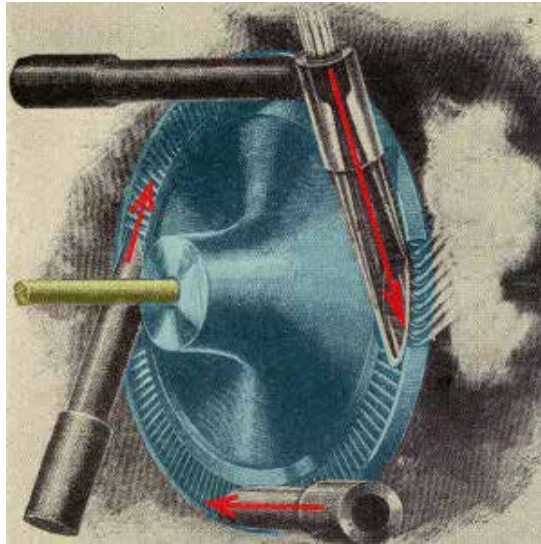

Fig. 7.5. Working principle of the steam turbine (Source: WEB-2)

Work of the work agent (steam or gas) flows through the shifting gears – nozzles (Fig. 7.5) falls on the curved linear blades, which are attached on the impeller, spins it and the flow goes out. By rotating the flow, a force occurs, which creates a torque that allows the work wheel to be fixed to the shaft in order to rotate.

Turbine – a thermal rotational engine (Fig. 7.6) which converts the thermal energy of a working body into mechanical work. The turbine (Fig. 7.7) consists of two main components:

1. Turning part – the rotor.
2. Rigged part – the frame (stator).

Before each disk with work blades (Fig. 7.6) there is an apparatus with mounted nozzles, which consists of several fixed nozzles, embedded into corps.

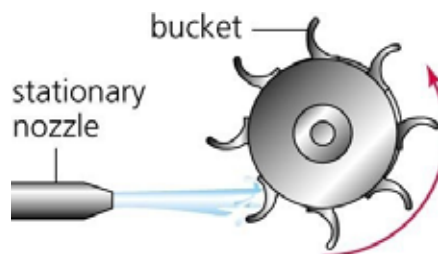

Fig. 7.6. Turbine's working wheel with a nozzle (Source: WEB-3)

The turbine is operated to be drawn up the differential pressure the nozzles and blades. Nozzles, together with blades, form the effusive part of the turbine. In the effusive part the working body undergoes a dual energy change:

1. The potential energy of the gas steam changes into kinetic in the nozzles. The flow rate, which comes out of the nozzles, makes up to one hundred meters per second.
2. In the work blades the kinetic energy of the flow changes into mechanical energy of the turbine's shaft rotation; the rotational movement. As a rule, it makes up to three thousand rotations per minute.



Fig. 7.7. Steam turbine (Source:WEB-4)

In the design of a steam turbine *rotating and rigged* pallets can be mounted. Rigged pallets (Fig. 7.8) are attached between the internal and external aperture rings.



Fig. 7.8. Aperture of the Steam Turbine (Source:WEB-4)

The rigged blade of the turbine is shown in Fig. 7.9:



Fig. 7.9. Turbine blade (Source: WEB-4)



Fig. 7.10. The Impeller's blades of the turbine's lower pressure part (Source: WEB-6)

In a multi-level turbine (Fig. 7.11) overheated steam, before entering a steam pipe 1 rebounds from the turbine's blades 2, it thus makes the impeller mounted on the turbine shaft rotate. Steam that works off the high-pressure turbine part, falls down the steam pipe into the low-pressure part of the turbine, which rotates the impeller.

Turbine's shaft 3 is connected with the shaft of an electricity generator. From the turbine's lower pressure part steam, through outgoing steam pipe, is redirected to the condenser of a steam turbine.

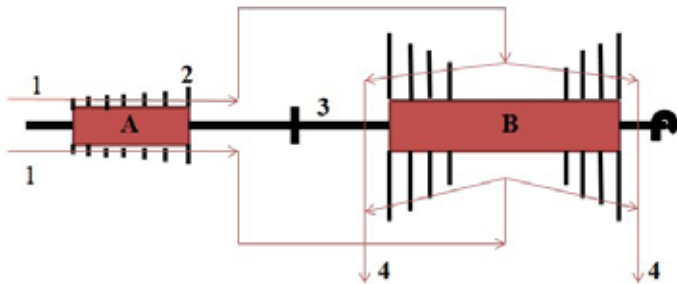

Fig. 7.11. Scheme of multi-level steam turbine: 1 – ingoing steam pipe; 2 – guiding blades of the turbine; 3 – shaft; 4 – outgoing steam pipe; A – high pressure block; B – low pressure block (Source: own elaboration)

The capacity of a steam turbine powered station depends on pressure's differential before steam enters the turbine and exits it. The capacity of steam turbines can reach up to 1000MW.

7.3. The classification of steam turbines

Depending on the nature of the thermal process, steam turbines are divided into three groups: 1. Condensing; 2. Thermal; 3. Special purposed.

7.3.1. Condensing Steam Turbines.

The purpose of condensation steam turbines (Fig. 7.12) is to maximize the topmost amount of heat of the steam and convert it into mechanical work. The steam produced in the turbine is redirected into the condenser, which is supported by vacuum.

Condensation turbines can be stationary and non-stationary.

Stationary turbines are made of one shaft with an AC generator. Such a device is called a *turbine generator*. Thermal power plants which are equipped with condensation turbines are called *condensing power plants*. The main final product is electric energy. Only a small part of the thermal energy is used in the plant for its own operational purposes. The higher the turbogenerator output is, the more economical it is and the lower the cost of installed power for 1 kW. Therefore, high power turbo-generators are installed in condenser plants.

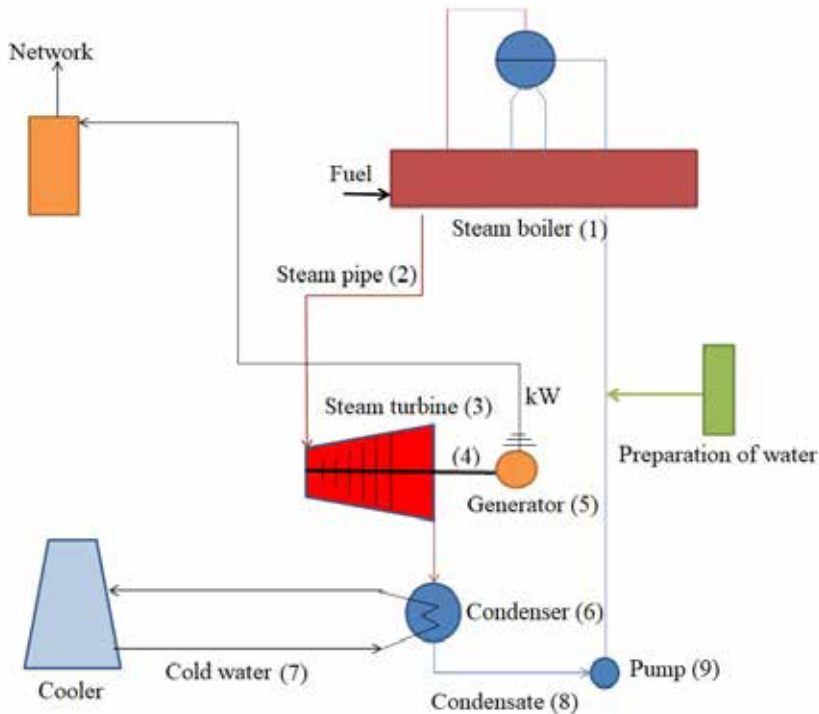

Fig. 7.12. Scheme of condensation turbine's work (Source: own elaboration)

Superheated steam from the boiler 1 gets in through steam pipe 2 on the steam turbine blades 3. While steam expands, its kinetic energy is converted into the turbine's rotor, which is at the same time connected with shaft 4 and to the electric generator 5, mechanical energy of rotation. The worked off steam from the turbine falls to a condenser 6, in which it gets in contact with the circulating water in the cooler 7, then it is cooled down to the state of water. The resulting, condensated with the help of the pump 9 is supplied back to the boiler with aid of the pipeline. The greater part of the gained energy is used for the generation of electrical current.

7.3.2. Thermal (cogenerational) steam turbines

Thermal steam turbines are designed to simultaneously produce electric and thermal energy, but the main and final product of these turbines is heat. Thermal power plants, which are equipped with thermal steam turbines, are known as cogeneration power plants. In these plants, steam turbines are assigned to pre-pressure, the regulation of

combined intermediate steam, as well as turbines of intermediate removal and pre-pressurization.

Turbines with pre-pressure are the ones where worked off steam is used in technology (e.g. drying, heating). Electric powers which these turbines achieved depends on the demand of production or the steam needs of heating system and it can vary according to needs. Therefore, a pre-pressure turbine generally operates in parallel with condensing turbines or an electric network, which cover deficiency of the electric energy.

The turbine, with controlled removal of steam parts for gathered of 1 or 2 degrees from intermediate turbine and the remainder, is redirected to the condenser. Thanks to the regulatory system, the gathered steam pressure is maintained within the task limits. The steam harvesting site (turbine's degree) is selected depending on the required steam parameters.

In turbines with intermediate steam removal and pre-pressure steam turbines, a portion of steam is withdrawn from the intermediate of 1 or 2 degrees and all the produced steam is redirected to the heating system or network of heaters.

Fig. 7.13 shows a scheme of how thermal steam turbines work.

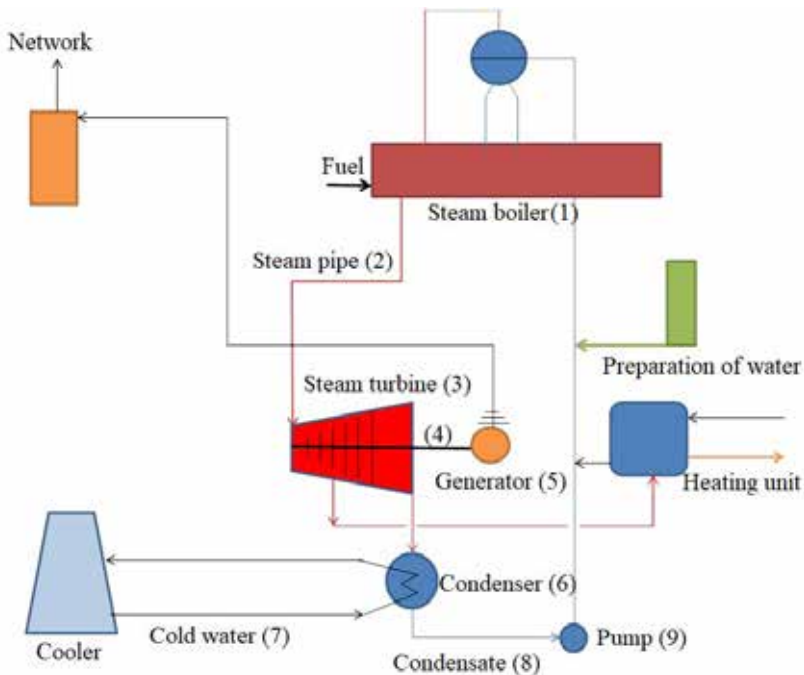

Fig. 7.13. Scheme of Thermal steam turbine work (Source: own elaboration)

The superheated steam from boiler 1 through steam pipe 2 is redirected to the steam turbine's 3 working blades of high-pressure cylinder (ASC). While steam expands in the turbine, its kinetic energy is converted into the turbine's rotor, which is connected to an electric generator 5 with shaft 4, rotating mechanical energy. While steam expands, steam is removed by low-pressure cylinders, which are supplied to the network 7 of water-heaters 6. Steam from the last level of turbine falls to a condenser, where it is condensed and after that through pipeline 8 to the pump 9 supplied back to the boiler. The higher portion of the heat, generated in the boiler, is used for heating the water network.

Advantages of steam turbines:

1. Steam turbines can operate by burning diverse fuel: gaseous, liquid, solid;
2. High capacity power;
3. Free selection of coolant;
4. Widespread range of capacities.

Disadvantages of steam turbines:

1. High inertia of steam installations (prolonged start and stop time);
2. High cost of steam turbines;
3. Relatively low volume of produced electric energy compared with the thermal energy.
4. Costly repairs of steam turbines;
5. Ecological indicators deteriorate by using oil and solid fuels.

In process of cogeneration 7-50% of the fuel energy is used for production of electric energy; 8-20% – turns into losses, while the rest portion of the fuel energy forms in a shape of steam or hot water, used in technology for building heating, and preparation of hot water.

Cogeneration plants can use various devices, which differ according to technical, operational, efficiency and several other aspects.

Cogenerational devices consist of four main components:

1. Primary engine.
2. Electric generator.
3. System of heat redirection.
4. Control system.

The different selection of technologies in cogeneration plants is determined by various factors: the required relation capacity of thermal and electric, thermal parameters and the fuel used.

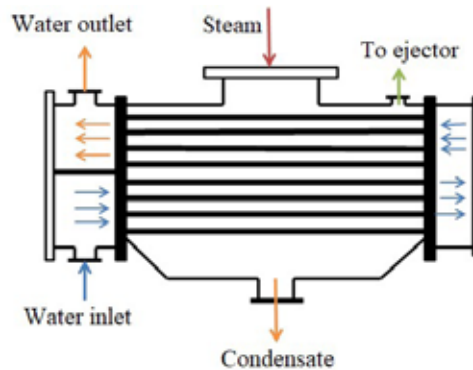

Fig. 7.14. Turbine's condenser principle (Source: own elaboration)



Fig. 7.15. Tubes of turbine's condenser (Source: WEB-7)

7.3.3. Pre-pressurized steam turbines

These turbines do not include condensers. The produced steam, which pressure is greater than atmospheric, falls into a special accumulation collector from which the heat is supplied to heat consumers or companies, for heating and production purposes.

The capacity, which is developed by a pre-pressurized turbine, totally depends from the load of heat user. Consequently, the installed capacity of a turbounit is utilized inefficiently. For this reason, pre-pressurized turbines are used to a limited extent.

In most cases, consumption graphs of heat and electric energy varies, so turbines operate according to the thermal schedule, it can not fully supply to consumers with

electric energy. Therefore, in modern energy systems pre-pressurized turbines do not work in isolation (separately), but in parallel with the condensing turbines.

In this case, pre-pressurized turbines produce only an exact amount of electric energy, which depends on the produced quantity of steam, supplied heat quantity; and other portion of the electric energy is produced in condensing turbines. The condensation turbine does not need to be in a power plant along with pre-pressurized turbines. It is important that their generators are switched on into mutual network of electricity.

In pre-pressurized turbines, all produced steam is used for technology (like heating, drying and so on). Electric power, which is developed by the turbounit pre-pressurized steam turbine, depends on the technology (production) or the needs of steam heating and it evolves along with them. Therefore, pre-pressurized turbounit normally works parallel to the condensing turbine or electrical network, which covers the resulting energy deficiency.

By selecting pre-pressurized turbine, the most important indicator is the volume of conducting steam and load schedule, according to which the turbine will work. Pre-pressurized turbine, by working according to the graph of thermal load, only covers part of electric load of energy; while the rest of the electrical load is covered with energy produced by condensation power plant. In the case of maximum thermal loads, heat is additionally supplied to the heat consumer as fresh steam if the amount of steam required for heat consumers exceeds the maximum of pre-pressurized turbine's penetrability.

If, for example, a pre-pressurized turbine is designed to serve the heating system, in this case the maximum load of the turbine is achieved during the heating season (in coldest months) when more heating is needed. During the summer, the turbine can not complete any load. Then the electrical equipment will be used. Therefore, purposeful usage of the pre-pressurized turbine is devoted for those heat consumers who uphold the heat load at the required level throughout the year, for example, in the chemical industry. In the case of steam, which is supplied to customers, pressure must be kept constant.

The simplest method is a scheme, in which the pre-pressurized turbine is used. With this method electrical and thermal energy is produced by the steam turbine (Fig. 7.16).

Power stations with the pre-pressurized steam turbine can create several tons of megawatts. The ratio of a typical production of electric and thermal energy makes up to 0.3-0.5. The cogeneration gas power plant turbine's capacity is slightly lower than power plants for steam turbines, but ratio of the produced electric and thermal energy, in many cases, reaches 0.5.

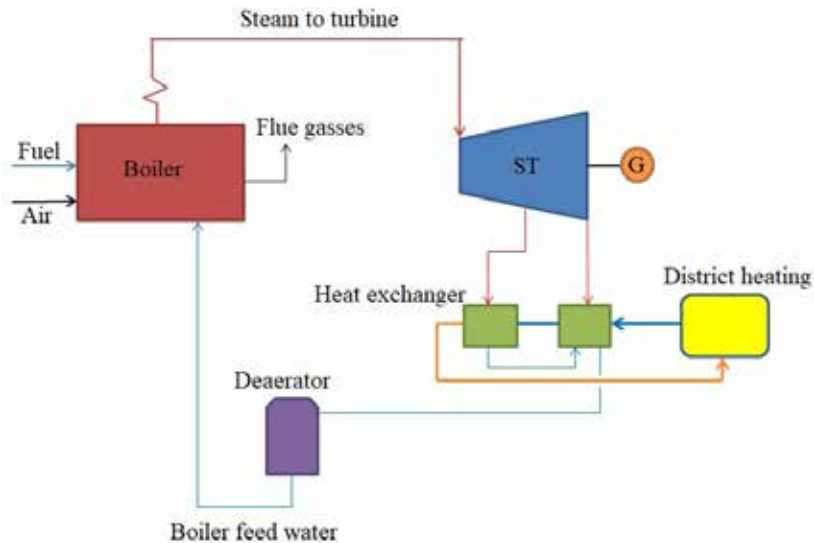

Fig. 7.16. Scheme of pressurized steam turbine (Source: own elaboration)

In devices with a pre-pressurized which is used in the industry, their capacity depends upon the used up electric energy by technological processes, as well as from properties as high pressure, medium pressure and pre-pressurized steam. An important characteristic of the pre-pressurized system is the ratio of electric and thermal energy.

The power, which is developed by a pre-pressurized turbine, totally depends upon the heat load by user, this turbounit installed capacity is utilized inefficiently. For this reason, pre-pressurized turbines are only used to a limited extent.

The technology of pre-pressurized steam turbine (Fig. 7.17) is a key equipment for a steam boiler with steam superheaters, steam turbine, electric generator and transformer substation.

Water is compressed by a supply pump to moderate (~ 4.0 to 6.0 MPa) or high (~ 6.0 MPa) pressure, it is **evaporated** in a steam boiler and a steam superheater, in which the steam temperature is increased to 400 - 600°C . Overheated steam in pre-pressurized steam turbine expands and reaches a pressure which is higher than the atmospheric pressure. Expanding steam at the turbine resulted mechanical energy in the generator is transformed into electric energy. Expanded steam can be supplied to the systems of district heating (CHS), industry companies, heat energy consumers and so on. The pressure of supplied steam ranges from 0.3 to 2.0 MPa. Steam of higher parameters can also be supplied to technology.

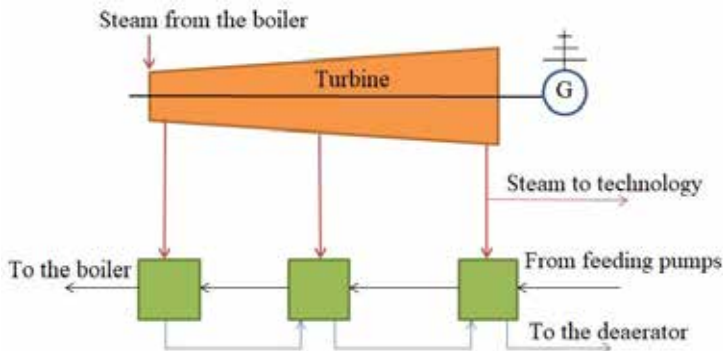

Fig. 7.17. The scheme of Thermal pre-pressurized turbine (Source: own elaboration)

The capacity of a steam turbine is usually regulated by a throttle situated against the turbine, which is shifting the pressure of inlet steam, in conjunction with mass flow yield, or injector system, which allows turning on or turning off individual injectors which are in conjunction with the first impeller. The temperature of steam overheating is regulated by collector's multiple re-heaters by injecting its own condensate; by invoking methods of recirculation of combustion products and reduction of contact temperature.

High electrical efficiency can be achieved only by producing an overheated steam of high parameters (600°C temperature and pressure of 17.0 to 22.7 MPa) uniflow (forced circulation) boilers.

In power plants, which are fueled by biofuels, steam parameters are limited because of the sulfur and chlorine in fuel, which increases the risk of acidic corrosion.

Power plants can burn these fuels: 1. Coal; 2. Oil Products; 3. Biomass and municipal waste; 4. Other fuel, which can be burned in a steam boiler.

In cogeneration plants, which operate on the principle of the pre-pressurized turbine, *electrical efficiency* only reaches 10-25%, while high capacity modern condensing power plant's electrical efficiency reaches 40-45%. Total condensing power plants steam turbines combined efficiency reaches up to 85%.

The elimination of pollutant emission quantities and types in the environment are associated with a type of fuel burned in a boiler, construction of combustion chamber and flue gas treatment installations. Nitrogen oxides (NO_x), sulfur oxides (SO_x), particulate matter (PM), carbon monoxide (CO) and carbon dioxide (CO_2) are emitted from a steam boiler.

During evaporation in water, salt falls out in form of lime and because of that salt must be removed from water. The products of precipitated salt and pipeline corrosion cause slimewhich must be disposed by continuously and periodically blowing out (or alternative word *scavenging*) the turbine.

Steam turbines are reliable. Their reaching service life is up to 50 years. The CHP plant with production of steam must be clean (no salts) and dry, bearing lubricant – at a suitable temperature, in enough quantity, which must be free from abrasive impurities. Maintenance is required by auxiliary equipment – pumps, coolers, filters, protective systems.

Due to different expansion of thermal coefficient of erratic various elements, turbines need to run relatively slowly.

Application: industrial and electric energy production plants, which electric capacity is from 0.5 to 300 MW and higher.

7.3.4. Condensing turbine housing

The condensation turbine housing is a special outlet, which conveys a non-fully expanded part (medium or low pressure) of steam from the middle part of the turbine. This steam can be used for heating drinking water in industry companies or in centralized heat supply systems.

The *operating principle* of condensation turbines is parallel to the pre-pressurized steam turbine's operating principle. The main difference is that in this cycle steam is needed, for heat energy consumers, is used as partially expanded. In this turbine the steam expands in a condenser, in which supported vacuum is higher. Steam in a condenser condenses and is returned to the boiler by feeding pumps, by which it is compressed to the required pressure for the process and additionally is deaerated.

By using this technology, heat and production of electricity can be regulated according to different thermal and electrical energy needs:

1. Removable steam pressure is controlled by valves, which are in the beginning of a steam gathering line (thus supported by steam parameters p and t).
2. At maximum demand of heat energy, the whole steam can be removed by being not entirely expanded (turbine middle section). At low demand of heat energy, this turbine can work at frequent cycle of condensation turbine, when the whole steam expands in turbine and condensed in the condenser, waste heat is emitted into atmosphere.

The main scheme of the main condensation turbine operation is shown in Fig. 7.18.

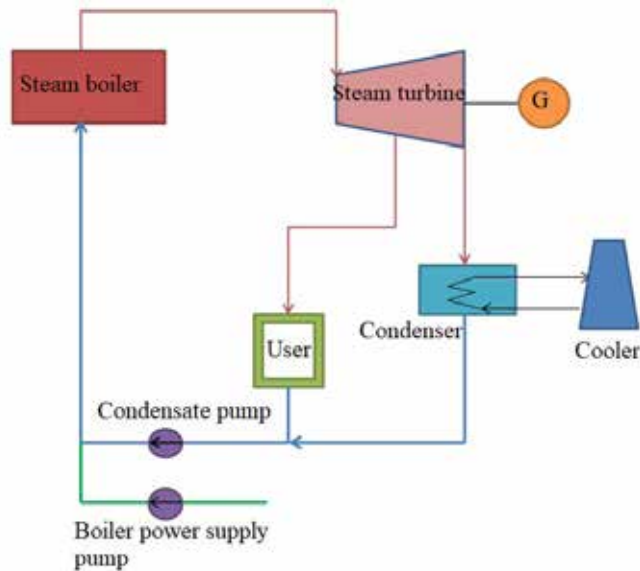

Fig. 7.18. Principal scheme of main condensation turbine operation (Source: own elaboration)

Usually, the capacity of the steam turbine is regulated by the throttle, situated against the turbine, by shifting the pressure levels of the inlet steam. Regulation can also be carried out by using a system of sprinklers, which allows turning on or off individual injectors which are in conjunction with the first impeller. The temperature of overheated steam is regulated by the recirculation of flue gas or injecting its own condensate to the collector of re-heaters.

The highest electrical efficiency can be achieved by producing steam of high pressure and temperature (17.0 to 22.7 MPa, 600°C). This mode is only possible for uniflow (forced circulation) boilers.

Used fuel types – natural gas, coal, petroleum products, biofuels and other.

Electrical efficiency of high capacity modern condensing station reaches 40-45%. Combined *efficiency* of steam turbine powered condensing stations reaches 85%.

This scheme of power station is applied to industrial and power companies, whose power station's capacity is higher than 0.5 MW, for meeting needs of fluctuating heat and energy.

7.4. Gas turbines

Gas turbines are types of cogeneration units.

The working principle of gas turbines is based upon the expansion of combustion products, in which there is compressed combustible gas and air mixture (Fig. 7.19). Combustion products expand in the gas turbine, it rotates shaft; mechanical energy is obtained. Large portions of mechanical energy are transferred to the air compressor for air compression, where compressor uses up to 50% of the turbine generated mechanical energy. About 20% of primary energy is converted into electric energy and 65% converted into heat.

The generation efficiency of electric energy unit reaches up to 25-35% of used fuel for heat.

7.4.1. The operating principal of Gas Turbines

The main body in gas turbines is a mixture of combustible fuel and air which enters the turbine at high temperature, from the combustor. Gas turbine is linked with one shaft, electric generator and air compressor, by compressing air up to terminal (required) pressure. The air compressor's pressure relationship with absolute air pressure before the compressor is called *pressure increase (compression) degree*.

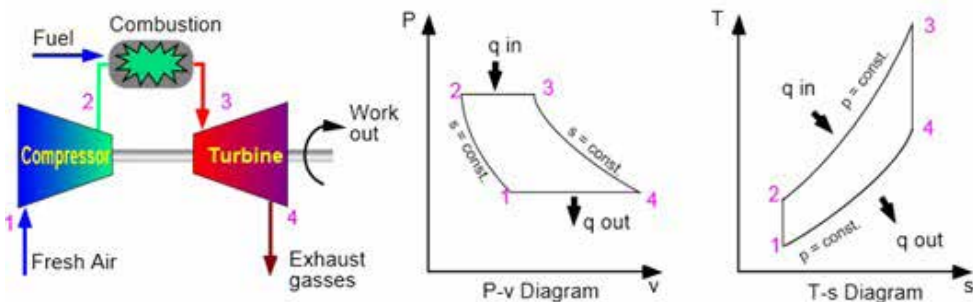

Fig. 7.19. The operating principle of gas turbine's work: 1 – fresh air to the compressor; 2 – compressed air to the combustion; 3 – high temperature combustion products to the gas turbine; 4 – worked off flue gasses. In p-v and T-s diagrams process 1-2 – *air compression* (pressure increases from p_1 to p_2 ; temperature – from T_1 to T_2); 2-3 – *combustion of air and fuel mixture* (heat emissions proceeds at constant pressure $p_2 = p_3$, temperature increases from T_2 to T_3); 3-4 – *gas expansion in turbine* (mechanical work is performed; temperature of gas decreases from T_3 to T_4 and pressure – from p_3 to p_4 ; $p_4 = p_1$); body of work cools down (Source: WEB-8)

The main portion of mechanical energy of the gas turbine's work is used in the compressor; the rest – for the production of electric energy in the generator (useful cycle of work).

7.5.2 Power plants of Gas Turbines

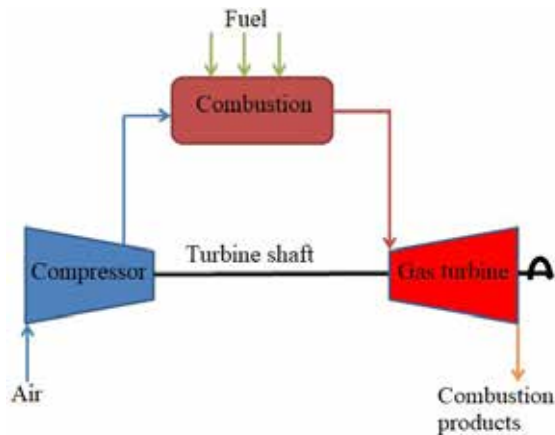

Fig. 7.20. Cycle of gas power plants (Source: own elaboration)

The compressor draws atmospheric air and it compresses up to high pressure. The compressed air is supplied to the combustor; in which it is mixed with fuel. During the combustion process high temperature flue gasses are formed, which expand into the turbine, performing work and releasing into environment. Part of the work in the turbine is used for the operation of a compressor, and the remaining – for the production of electric energy.

7.5.2.2. Regenerative gas turbines

Portion of discharged heat from the turbine can be used in heat exchanger-regenerator (Fig. 7.21).

As showed by Švenčianas & Adomavičius (2011) supplied air in the combustor is heated by running gas in the regenerator. This way, the quantity of fuel delivered to the combustion chamber is reduced.

Worked off outgoing combustion products from the turbine (state 4), exiting air from compressor is heated (state 2). Heated air from regenerator's parameters is supplied to the combustor, where fuel mixing with air and ignition takes place. Products from

combustion (state 3) enter the gas turbine, in which they expand by performing mechanical work. Combustion products, given up heat, cool down to state b and are emitted into the atmosphere.

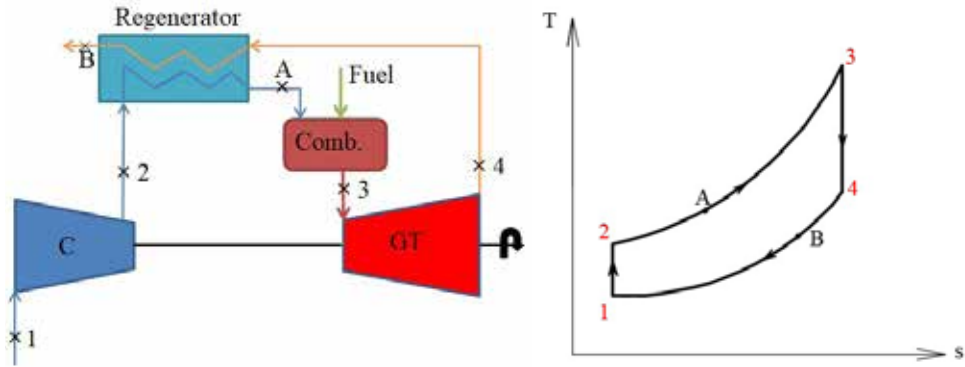

Fig. 7.21. Cycle of Gas power plants and T-s diagram (Source: own elaboration)

In T-s diagram (Fig. 7.21) the process 1-2 – air compression in the compressor (lifting air parameters); process 2-A – air heating in the regenerator due to combustion products; Process A-3 – air mixing with fuel in the combustor and burning, which results in a high-temperature combustion product, which enters the gas turbine and expand in it, performing work. If a regenerator was not included in the scheme, the combustion process would take place under the curve 2-3 (then, fuel consumption would be increased). The highest temperature T_a , up to which air can be heated, is the waste gas temperature T_4 .

The cycle of the turbine repeats anew.

7.5.2.3. Multi-level regeneration gas turbines

Gas turbine with intermediate combustor is shown in Fig. 7.22.

The metal of a turbine must withstand the high temperatures of combustion products, thus flowing into the turbine gas temperature must be limited. This is achieved by supplying more air to the combustion chamber than is strictly needed for fuel combustion. The combustion products will come out from the combustor, which will receive enough oxygen for a certain amount for burnt fuel. The intermediate combustor will be supplied with enough extra fuel.

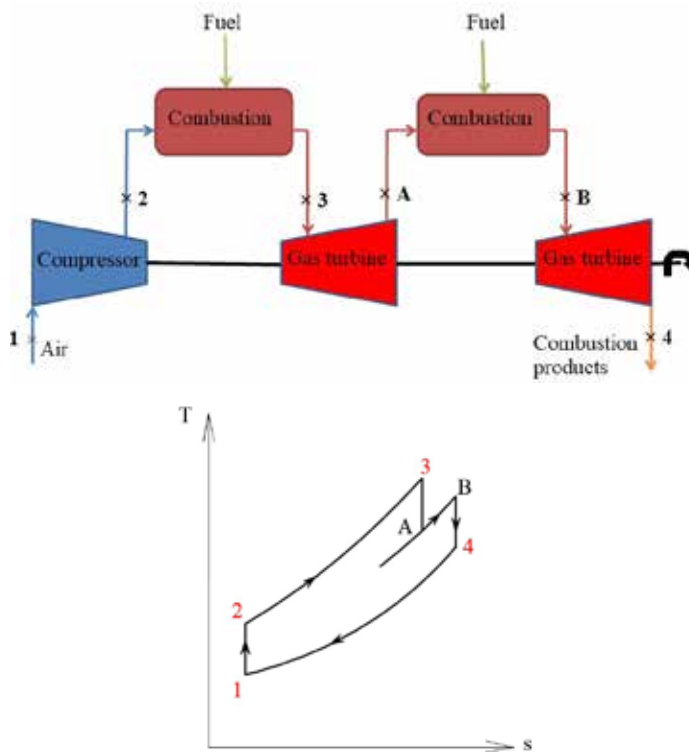

Fig. 7.22. Gas turbine with intermediate combustion chamber and cycle in T-s diagram (Source: own elaboration based on Švenčianas & Adomavičius, 2011)

In T-s diagram process 1-2 – air compression in the compressor (air temperature and pressure increases); process 2-3 – the combustion of fuel and air mixture, the formation of high temperature combustion products; process 3-A – adiabatic expansion of combustion products in the first level of the turbine (mechanical work); process A-B – intermediate temperature rise of the combustion products by supplying additional fuel; process B-4 – expansion of combustion products in the second level of the turbine.

If the maximum admissible temperature of the combustion products is in state 3, so we see in the T-s graph that the temperature of the combustion products from the intermediate combustion chamber (I. Comb.) will be lower (state B) allowable, but high enough that it could be exploited during the installation regenerator. Intermediate heating IC (*intermediate combustor*) together with thermal regenerator increases thermal useful coefficient (coefficient of efficiency).

7.5.2.4. Combined cycles of gas and steam turbines

In order to increase the efficiency of power plants, the combustion products are emitted from the gas turbine, which can be used for the next cycle, for example, in recovery boiler with a steam turbine (Fig. 7.23).

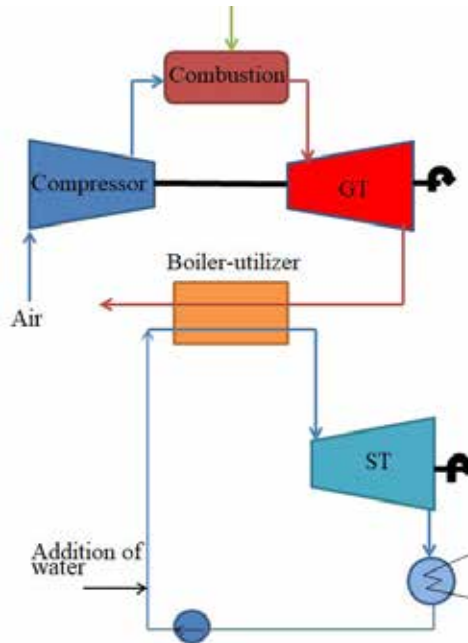

Fig. 7.23. Cycle of steam and gas (Source: own elaboration)

The worked off high temperature combustion products are redirected to the boiler – utilizer, in which the temperature of combustion products is raised to the required temperature by supplying a certain amount of fuel and air mixture to the boiler.

After reaching the needed temperature of combustion products, steam is produced in a boiler-utilizer, which is overheated in superheaters up to the necessary parameters. This superheated steam is supplied to the steam turbine, where by expanding performs mechanical work, which is transmitted to the generator shaft. The steam from turbine's last degree is led to the condenser, in which it turns into liquid and is returned back by the pump to the boiler (Kilait & Puodžius, 2007).

General view of the gas turbine is shown in Figs. 7.24, 7.25 and 7.26.

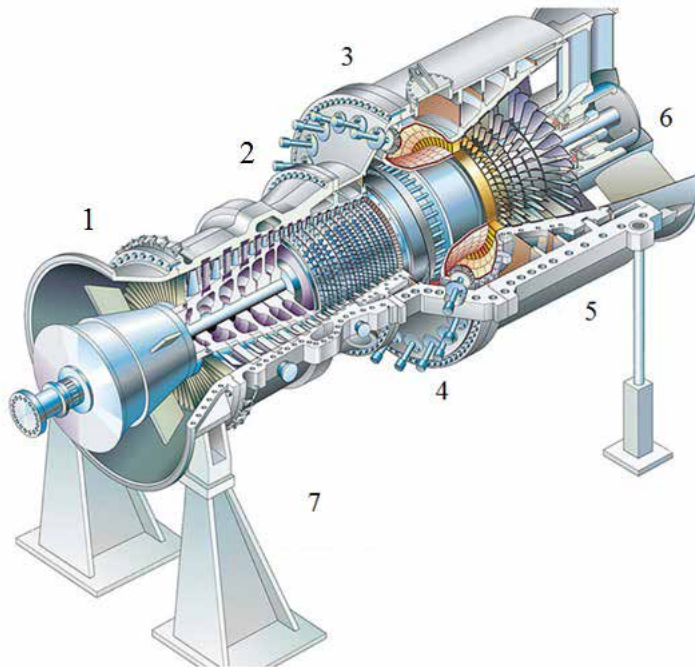

Fig. 7.24. General view of the gas turbine: 1 – air falls to the compressor through the intakes of air channels, in which air filters and noise dampers are installed; 2 – compressor rises air pressure to 16 bar; 3 – compressed air is supplied to the burners, installed in the combustor; 4 – gaseous fuel burns in the chamber, in which 24 burners are installed; 6 – the worked off gas is released through the axial diffuser and used for steam production in the steam boiler, from which steam of high parameters is supplied to the turbine; 7 – electric generator is connected with rotor of the gas turbine from the side of the compressor through an intermediate shaft and reductor, which reduces rotational speed of the turbine's rotor (5400 rot./min.) to the rotational speed of the generator (3000 rpm. or 3600 rpm.) (Source: WEB-9)

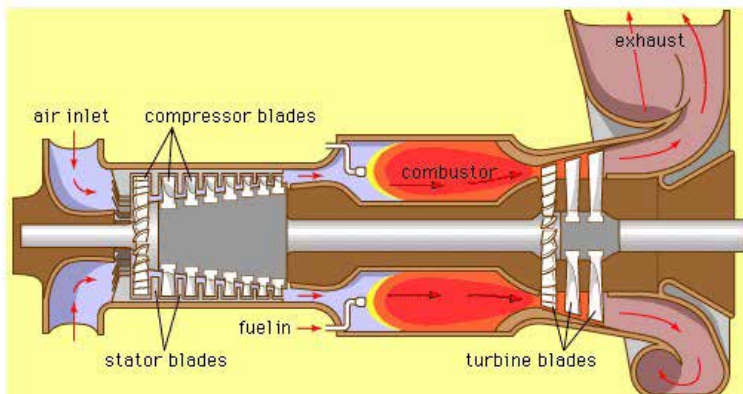

Fig. 7.25. Gas turbine (Source:WEB-10)

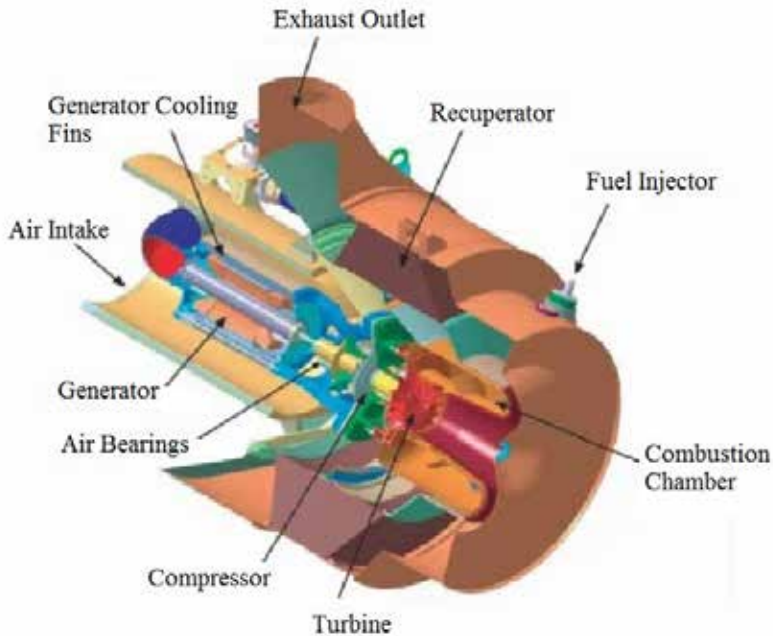

Fig. 7.26. Gas turbine (Source: WEB-11)

7.5.3. Combined cycle of gas turbine with recovery system

The main equipment of this system consists of:

- gas turbines,
- steam turbines,
- heat recovery system – steam generator or boiler-utilizer,
- electric generators,
- transformer substations.

Without the main equipment, standard control and auxiliary systems are also assigned (eg. compressed air, fuel, water or steam provision, etc.).

For the combined cycle, the gas turbine must be equipped with a *condensing steam turbine*, which may have some intermediate vapor removal systems.

Typical cogeneration plant with a 2-shaft combined cycle gas turbine technology is a key scheme (Švenčianas & Adomavičius, 2011) shown in Fig. 7.27.

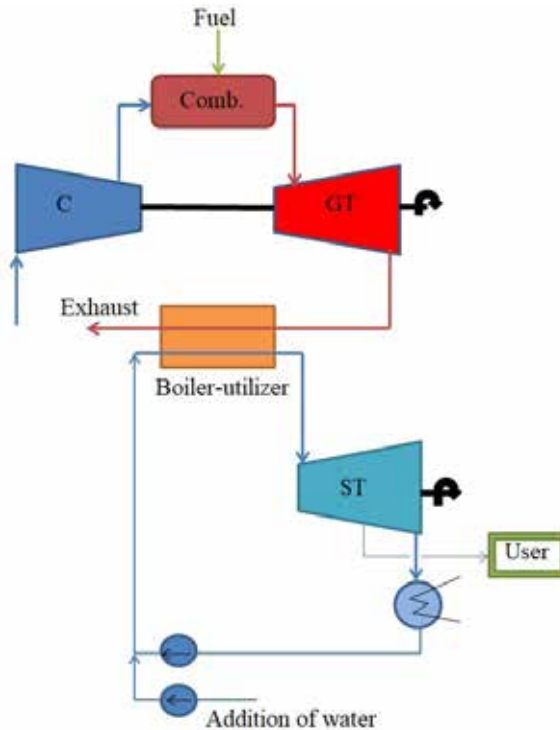

Fig. 7.27. Scheme of combined cycle of gas turbine with heat recovery system (Source: own elaboration)

The operating principle is as follows: the fuel pressure prior to combustor must not be lesser than 20 bar (2.0 MPa). For fuel injection into the combustor, when pressure is below 20 bar, the compressor is necessary to compress air, if liquid fuel oil is burnt – the pump is used.

Air, necessary for combustion, falls to the compressor through special openings of the gas turbine. Before air entering the compressor, it should be purified with filters. In winter time, when supplied to the gas turbine, the air must be heated in order to prevent the formation of ice in the inlet. Air heating can be employed in lubrication system of low parameters by installing heat recuperative systems. It would lead to a higher efficiency of the power plant. Once air gets into the compressor, it is compressed in several stages and its temperature is raised about 400°C.

By burning fuel and air mixture in the combustor, combustion products are obtained, which temperature is about 1200°C. The higher the temperature of combustion products, the higher the efficiency of the gas turbine. Temperature of combustion products is limited, since in high temperatures, nitrogen oxides (NO_x) for mechanical properties of gas turbine's components are deteriorating.

Combustion products expand in a multi-staged turbine. Mechanical energy, produced during this process, is used to rotate the compressor and generator. About 50-60% of the mechanical energy is used to pressurize the air in the compressor. In the gas turbine's existing outlet, the temperature of combustion products reaches about 500-600°C.

Combustion products fall into the steam's boiler-utilizer, where they can still be heated additionally by burning fuel up to 1000°C. Since combustion products still contain about 15% oxygen, air for combustion is sufficient.

Cooled fumes from boiler are emitted into the environment. In order for technological process to be effective, the temperature of combustion products should reach 70-80°C. Water vapor, existent in combustion products condenses at lower temperatures, by intensifying the surface corrosion. In addition, the temperature of combustion products should satisfy the consumer's thermal energy needs. By burning natural gas, the mentioned factors can be fully or partially prevented.

Water, supplied for steam production, is compressed by feeding pumps to required pressure. In steam boiler-utilizer, water is heated in several stages by out-going combustion products from the gas turbine. The steam is separated from the water in the upper drum and unevaporated water is recirculated in the system – that is returned into the drum. Steam in steam superheaters is overheated to 400-600°C and supplied to the steam turbine. Steam, expanding with speed of ~ 700 km/h in the turbine, bounces back into the turbine blades, in which steam's kinetic energy is converted into mechanical energy of rotation and thus rotates the shaft and it rotates the electricity generator respectively. Partly expanded steam, via dedicated steam drainage holes, could be directed to users or to a heat exchanger, in which steam releases its heat for heating thermo admission water. Work off steam from the turbine's last degree is redirected to the turbine's condenser, in which it condenses. The condensate is cleaned, deaerated and supplied by feeding pumps back to the boiler.

The capacity of the gas turbine is regulated by changing the amount of fuel supplied to the injectors. The steam turbine is regulated by changing the steam parameters of the steam boiler, which operation mode is directly related to temperature of the combustion products exhausted from the gas turbine. Another way – the turbine can be adjusted by against situated throttle, by shifting pressure of the inlet steam. You can also adjust the sprinkler system – by turning off or turning on individual injectors, situated against the first impeller of the turbine thus adjusting mass flow rate of the steam, and at the same time capacity of the turbine.

From an economic point of view, this type of cogeneration system can be applied only to a *thigh demand for electricity*.

Used types of fuel:

- Natural gas;
- Low-sulfur petroleum products;
- Coal or biomass gasification products.

The electrical efficiency of gas turbine, at the combined cycle, could reach up to 60%, while the *overall efficiency of the power plant* – 92.5%. By increasing electrical capacity of the cogeneration power plant, it also increases electrical and the overall efficiency of the system.

7.6. Microturbines

These are small gas turbines, which electrical capacity ranges from 25-30 up to 350 kW. Microturbines have a small number of moving mechanisms. In order to turn them, gas and liquid fuel can be used. By burning fuel in the turbine, rotary motion is created, which is transmitted to the electric generator shaft. Worked of combustion products in the turbine still are high parameters, so they can be used for heating air intake in the heater (or heat production).

The microturbines (Fig. 7.28) operating principle is similar to the gas turbine. It consists of two main components – the compressor and gas turbine. Supply air heater is installed in the microturbines (heat exchanger). Exchanger uses heat of the combustion products for heating air intaking, thereby increasing the efficiency of microturbines.

Air, by initial parameters, falls through the air filter, which is used for air cleaning and reduction of engine power losses. The filtered air, by passing through the generator, cools down the stator (fixed part linked to a movable rotor) windings; this allows rejection of the generator's cooling system. Compressed to the necessary parameters air falls to the heat exchanger (exchanger). Thanks to the exchanger, electrical efficiency of the microturbine is increased, allowing the reduction of fuel consumption. Heated and compressed air, supplied through the combustor, mixes with fuel and ignites.

Mixture combustion takes place at a constant pressure (Brayton cycle) and low working temperatures; it allows to achieve minimal emissions of pollutants to the atmosphere.

Energy, produced by ignited mixture, gone through the turbine turns into work. High-temperature hot gases, entered through the turbine nozzles, expand; during expansion thermal energy is converted into kinetic energy. The kinetic energy of the

gases enters the turbine rotor part, transforming into mechanical energy (movable part) of the rotor. Power distribution in the turbine is like this: part of the capacity is utilized by the compressor, the other part is an useful power of shaft. For starting, microturbines accumulators are used to compensate load of the current (when the engine starts to gain speed).

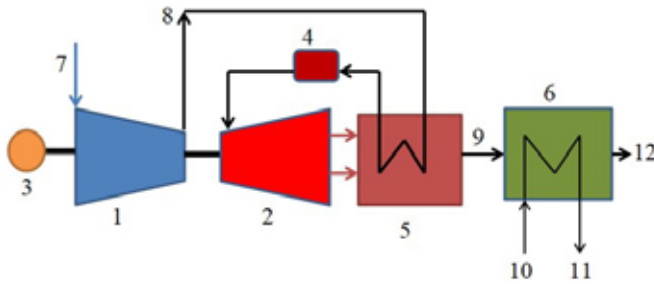

Fig. 7.28. Scheme of gas microturbine with heat regeneration: 1 – The compressor; 2 – Gas-turbine; 3 – Generator; 4 – the Combustor; 5 – Heat exchanger; 6 – Heat exchanger for worked off gases; 7 – Air; 8 – Air supplied to the regenerator; 9 – Worked off gases; 10 – Water supply; 11 – Hot water outlet; 12 – Ejection of worked off gases (Source: own elaboration)

From the exterior, the filtered air falls into the compressor and is compressed. The compressed air from the compressor enters the recuperator, in which it is heated by gas emissions from the turbine. The compressed heated air is supplied to the combustor and mixes with fuel. Fuel-air mixture burns in the combustor; high temperature compressed gas forms. Gas from the combustor falls into the turbine and by expanding gives away its energy to the turbine's rotor. The rotor, in turn, forces the power generator to rotate via reducer. Turbine's rotor also spins the compressor's, which is connected with the single-shaft of the turbine, rotor. Flue gases from the turbine makes way to a recuperator, in which it heats the air, supplied to the combustor.

The ambient air is intake into the centrifugal compressor and is compressed. If microturbine has air heater (exchanger), then compressed air is heated thanks to the heat of flue gases from the turbine. The compressed and heated air is supplied to the combustor, in which it is mixed with fuel and ignites. When fuel is burnt, received gas expands and turns the turbine's impeller and then exits through the heater, by giving out heat to the heated air.

The operational principle of the microturbine is illustrated in Fig. 7.29, as well as various temperatures in the characteristic points of the system.

The purified atmospheric air falls into the air debitometer 4, from which it is supplied to the compressor 3. In the compressor air is compressed; the temperature of the

compressed air rises to 250°C. After the compressor air enters special gas-air heat exchanger 10 (recuperator) where it is further heated to 500°C. Using the recuperator, the efficiency of the electrical device can be increased 2-fold.

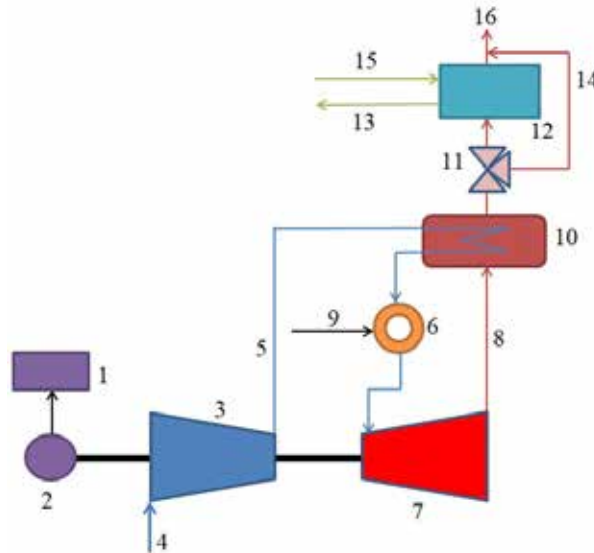

Fig. 7.29. The working principle of the microturbine: 1 – control electronics; 2 – electric generator; 3 – air compressor; 4 – air debitometer; 5 – duct between the compressor and exchanger; 6 – the combustor; 7 – turbine; 8 – flue between the turbine and exchanger; 9 – supply of natural gas; 10 – exchanger; 11 – bypass seal; 12 – boiler-utilizer; 13 – hot water outlet; 14 – bypass flue; 15 – cold water inlet; 16 – exhaust (explosion) tract; 17 – compressor (Source: own elaboration)

Hot compressed air, prior to the combustor 6, is mixed with high-pressure gaseous fuel 9 and homogeneous gas – air mixture falls into combustor. Air mixing with gaseous fuel reduces emission levels of flue gas up to 24 ppmv at 15% of oxygen.

When leaving the combustor, the exhaust gas is heated up to 926°C temperature, falls to the turbine's impeller 7, where by expanding performs work (rotates a turbine wheel), as well as on the shaft and the compressor's impeller 3 and an electricity generator 2.

From the turbine 7 emitted gas (648°C) by flue 8 falls to the recuperator 10, in which all the heat is returned to the air, after the compressor. The temperature of the exhaust gas after recuperator reaches 287°C.

By exiting recuperator 10, where bypass seal is equipped, which redirects exhaust gas or bypass flue 14, or directly to the boiler-utilizer 12. In the boiler – utilizer (gas-water heat exchanger), entire exhaust gas gives away all the heat to the water network, which heats up to the set temperature. The temperature exhaust gas drops to 77°C.

The structure of the microturbines does not include any reductor. The rate of the rotor's speed doesn't depend upon the load and is supported in the level of 68 thousand. r/min. (rpm).

Recuperator – is counterflow heat exchange (Fig. 7.30), from which heat of the exhaust gas exits the turbine and is transferred to the air from the compressor. Thereby the coefficient of the engine efficiency is increased.

The combustor is integrated into recuperator's node. The fuel, in the combustor, is mixed with heated air in the recuperator and ignited. Fuel – air mixture ignites from an electric spark of the igniter. Hot compressed gas, fallen into the turbine, spins the impellers.

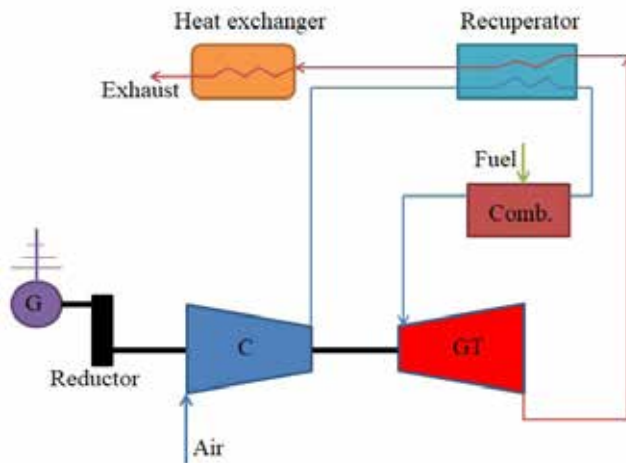

Fig. 7.30. Microturbine with recuperator (Source: own elaboration)

In one shaft microturbines (Fig. 7.31), the compressor and the turbine are mounted on the same shaft as the electricity generator.

Shaft's bearings can be cooled off with oil or air. One shaft microturbines are reliable; because they are generating rotational movement of high-frequency (60 000 rpm.). In the electricity generator, electrical current of altering frequency is generated, which is balanced by electric current rectifier. The resulting current is obtained, which later is changed to altering current.

By starting a microturbine, energy is received from the generator. If a microturbine is not connected to the electricity grids, the accumulator of electrical energy (battery) is required to start the turbine. Startup takes up to several minutes.

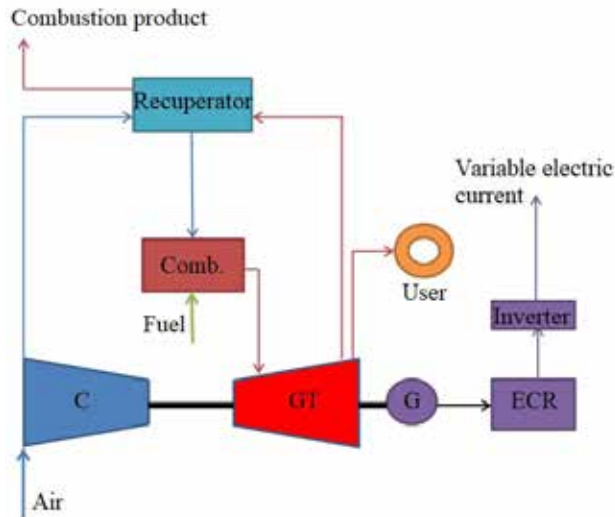

Fig. 7.31. Basic scheme of one shaft microturbine of the cogeneration power plant (Source: own elaboration)

Received thermal energy from the microturbine can be used for water heating or steam production of low parameters. Cogeneration plants based upon microturbines can supply heat and small commercial buildings like: restaurants, hotels, offices, and small industry companies.

7.7. Internal combustion engines

Internal combustion engine (ICE) – thermal engine, where fuel burns directly in combustion chamber, located in engine’s interior. Like every thermal machine, ICE converts thermal energy of burning fuel to mechanical work.

7.7.1. Schemes of working internal combustion engines

Internal combustion engine (ICE) – thermal engine, in which fuel burns in the engine’s working chamber (inside). Thermal energy of ICE fuel is converted into mechanical work.

Depending from the type of burning fuel ICE is classified into liquid and gaseous. According to the cycle of work – continuous operation, two and four stroke.

According to the preparation method of burnt mixture – external (for example, carburetors) and internal (for example, diesel) mixing.

According to the energy conversion – reciprocating, turbine, reactive and combined.

According to the coefficient of efficiency – 0.4-0.5.

The first internal piston combustion engine was constructed by French inventor E. Lenuar in 1860 (Fig. 7.32). This title appeared by perceiving the working principle: fuel is burnt in an engine itself, rather than on the outside, more precisely – in its cylinders. However, the first ICE really was not that good and its efficiency coefficient was very low. After a period of time, ICE has been improved and replaced by a newer model.

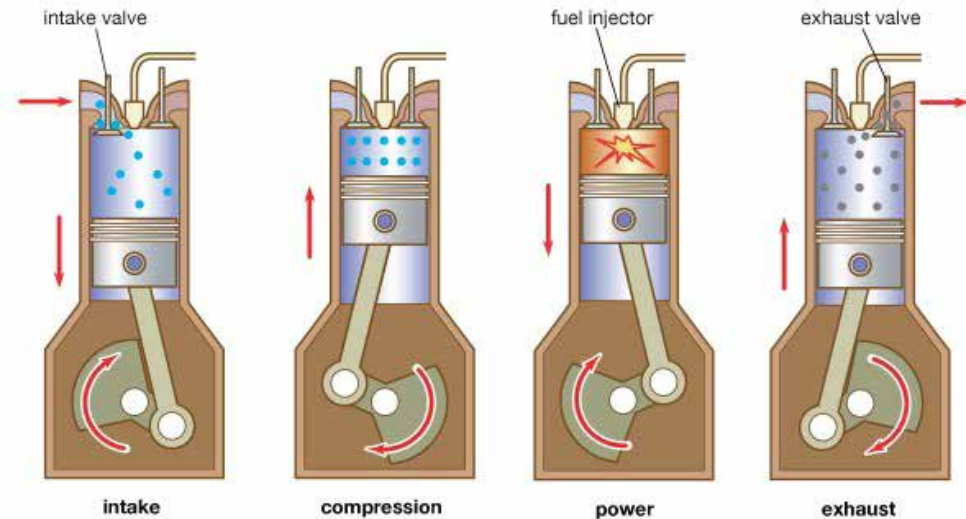

© Encyclopædia Britannica, Inc.

Fig. 7.32. Working principle of internal combustion engine (Source: WEB-10)

Burnt fuel and released heat in all ICEs is converted into mechanical work. For fuel combustion, oxygen is required; for this compressed air is used. Work is the body for ICE combustion products. For fuel combustion in the engine, there is a prepared work infusion by mixing fuel and air mixture. In external mixing engines, a working infusion work is prepared in the mixer and supplied to the cylinder, which is ignited by an electric spark. These engines have low compression ratio for fuel mixture. In the internal mixing engine, mixing of fuel and air does not occur early, so each one is supplied to the working cylinder separately, in where they are mixed to form a work mixture.

Stroke of work I cycle (Fig. 7.33) takes place in an intake of work mixture into the cylinder. In II-stroke the mixture is compressed; in stroke-III the mixture burns down and formed gas presses the piston, by pushing it from the top down, and at the same time performing mechanical work. A piston's motion through the piston-rod mechanism is transferred by the engine's shaft. IV-stroke products of combustion through the drain valve are expelled to the atmosphere.

Four-stroke ICE work is regulated by the gas distribution system, consisting of inlet and outlet valves.

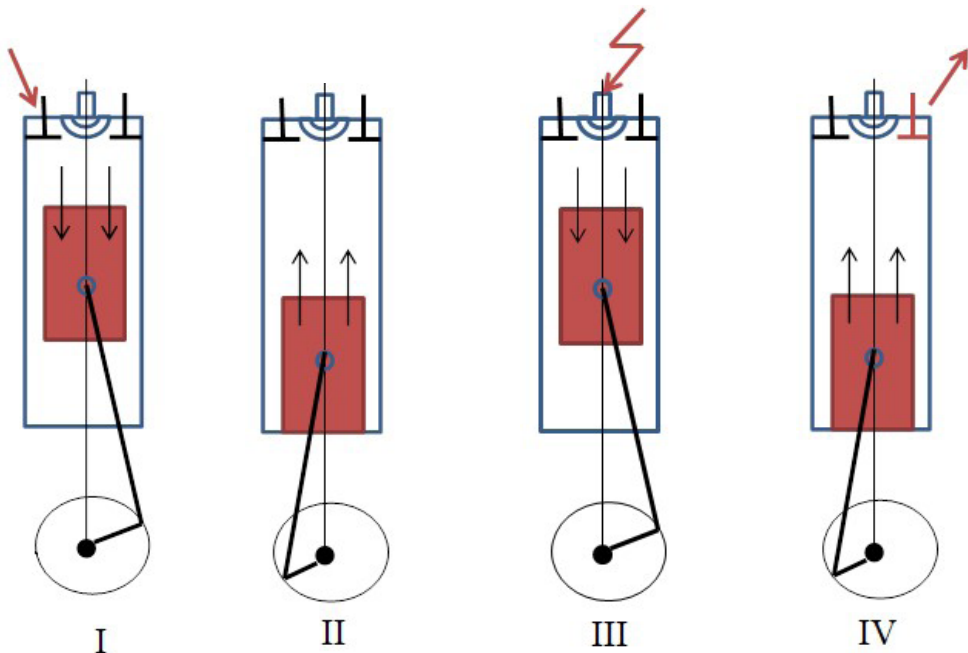

Fig. 7.33. Working scheme of four stroke carburetor ICE: I – intake; II – compression; III – burning; IV – exhaust (Source: own elaboration)

Working principle of a fourstroke engine is presented in Fig. 7.34.

Four-stroke engines operating principle is described below:

1 – intake;

The piston (5) by going down the cylinder decreases pressure (9). Due to the resulting pressure difference through the opened intake valve (11), a fresh mixture is absorbed.

2 – compression;

The intake and exhaust (2) valves are closed. The plunger rises upwards by compressing the suction mixture in the combustion chamber.

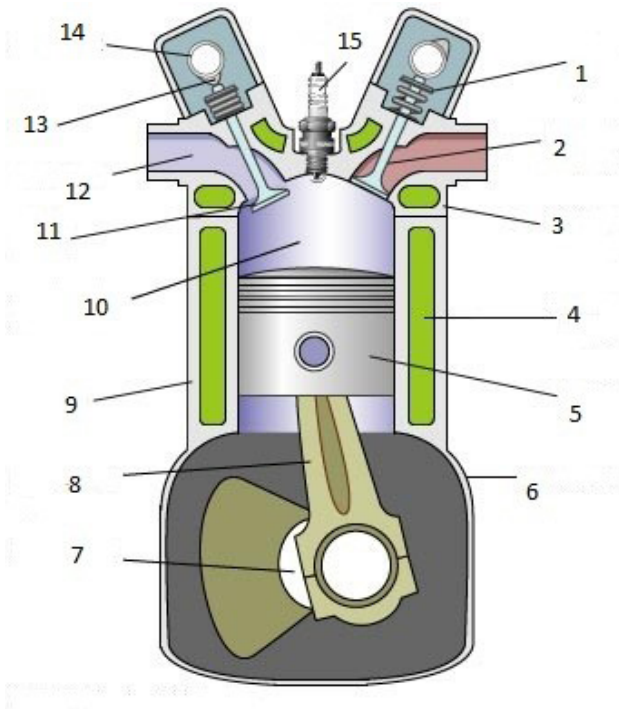

Fig. 7.34. Four-stroke engine components: 1 – valve spring; 2 – exhaust valve 3 – cylinder head; 4 – coolant; 5 – piston; 6 – carter; 7 – a crankshaft; 8 – connecting rod; 9 – cylinder; 10 – combustion chamber; 11 – suction valve; 12 – suction hole; 13 – cam; 14 – roller; 15 – candle (Source: WEB-12)

3 – an explosion;

When the piston almost reaches the „death” point, spark ignites the mixture. In the event of an explosion, the piston is pulled down.

4 – discharge.

Pushed down piston rises up again. An exhaust valve up and burnt mixture is removed through the exhaust port. The cycle repeats itself again.

Two-stroke ICE is easier to install (Fig. 7.35). There, the intake of hot mixture and its initial compression takes place outside of an engine’s low-pressure cylinder.

In these engines, the complex gas distribution system is replaced with three rows of ports 6 and 8 in the side surface of the cylinder 3. Through these ports worked off gas is released, the engine’s carter intakes working mixture and cylinder is purged from residues of combustion products. The ports are opened and closed by the piston itself 10 (its surface) while moving by the cylinder.

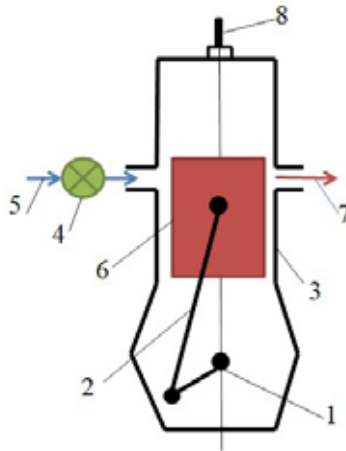

Fig. 7.35. Two-stroke carburetor ICE: 1 – shaft; 2 – piston – rod mechanism; 3 – cylinder; 4 – pump; 5 – fuel, air; 6 – piston; 7 – products of combustion; 8 – the spark plug (Source: own elaboration)

Stroke I (Fig. 7.36) moves by piston from the bottom, foremost when combustible mixture is compressed in the cylinder, and after that to the engine's carter from the carburetor when the new amount of combustible mixture is intake. When the compression of the working mixture ends, it flares up from the electric spark. The expansion of combustion products takes place in **Stroke II**. They push the piston down, that is to say, the work process occurs (motion).

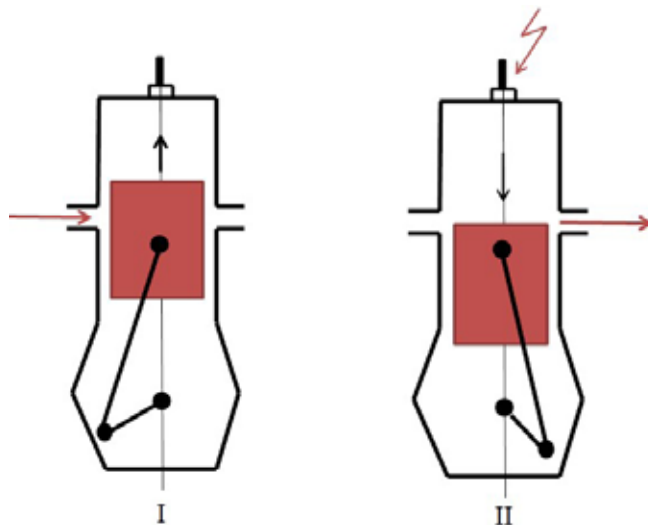

Fig. 7.36. Two-stroke ICE (Source: own elaboration)

When the piston moves from the top down, emissions are released into atmosphere.

In low compression engines, in which light liquid fuel is burnt (eg. petrol) mixing of the mixture takes place in a special device – the carburator.

ICE are widely used in industry, automotive, aviation, marine and rail transport.

The advantages and disadvantages of fourstroke ICE comparing with twostroke engine:

Advantages:

1. Four-stroke engines generate considerably higher torque, especially at low speeds;
2. Consumes much less fuel; Slower, due to better lubrication;

Disadvantages:

1. The four-stroke engine has many rotating and moving parts;
2. More complex maintenance and repairs;
3. Four-stroke engines are more expensive than two-stroke engines.

7.7.2. Power plant with internal combustion engine

Internal combustion engine is a widespread technology, by the means of which the electric power ranges from 2 kW to 5 MW. Internal combustion engines in cogeneration plants without electric energy, also produce hot water or steam of low parameters in boilers-utilizers. In the internal combustion engines, electricity is produced more efficiently than in gas turbines, but usage of surplus heat is more complicated, as it is distributed between the engine's cooling system and exhaust gas.

There are two main types of internal combustion engines which are suitable for production of electric energy. Engines based upon Otto's cycle, in which fuel-air mixture is ignited by a spark, and diesel engines, in which fuel and air mixture ignites by itself upon compression, when pressure firmly increases and the temperature of mixture rises up to the threshold of flash.

In most cases, Cogeneration plants (Fig. 7.37), use operating reciprocating internal combustion engines based upon Otto cycle. Fuel energy is transformed into mechanical shaft work due to the volume expansion of the exhaust gas and thermal energy during the combustion of the mixture. The thermal energy can be extracted from the worked off gas and (or) redirected from the cooling environment of the engine.

Gas (natural gas or landfill gas, biogas) or fast evaporating liquid fuel (gasoline, propane) are used in Otto cycle engines. Natural gas fits the most is to produce electric energy.

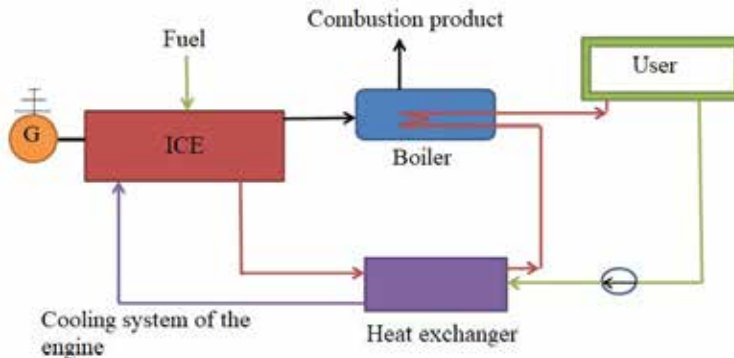

Fig. 7.37. Cogeneration plant with internal combustion engine (Source: own elaboration)

By using an internal combustion engine (Fig. 7.38), the utilization of lubricant oil, cooling water, as well as heat of exhaust gas is applied. Internal combustion engines' (ICE) chemical energy of ignited fuel is converted into thermal energy.

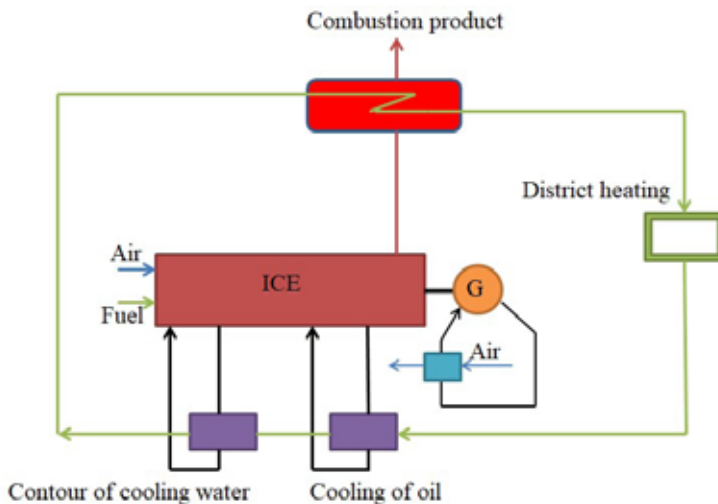

Fig. 7.38. Cogeneration plant with internal combustion engine (Source: own elaboration)

During the combustion, formed smoke fumes expand in the gas cylinder and force the piston to move. Mechanical energy, with support from the piston shaft, is transferred to the flywheel, and then thanks to the AC generator, mechanical energy is converted into electrical energy.

The most common types of ICE are a diesel engine with a spark ignition. In these ICE gas and liquid fuels (including oil and natural gas), bio gas, diesel fuel, crude oil, heavy fuel oil and refinery waste can be used for burning.

The exhaust gas is about 30% of energy released by burning fuel, and in flows of cooling water – about 20%. The energy of exhaust gas can be utilized in a boiler-utilizer or heat exchanger, in which it can be used for production of steam, hot water or hot oil. Furthermore, hot exhaust gas can be directly or indirectly (in heat exchangers) exploited in various technological processes (for example, like drying).

Flows of cooling water can be redirected to the contours of high and low temperatures. The utilization potential of water's thermal energy depends from minimum temperature, which is needed for the needs of users. The potential of cooling water can be fully exploited by district heating systems with low return water parameters.

Using ICE only for electricity production, their efficiency coefficient reaches up to 40-48%. By applying effective heat utilization in cogeneration schemes, this coefficient may reach up to 85-90%.

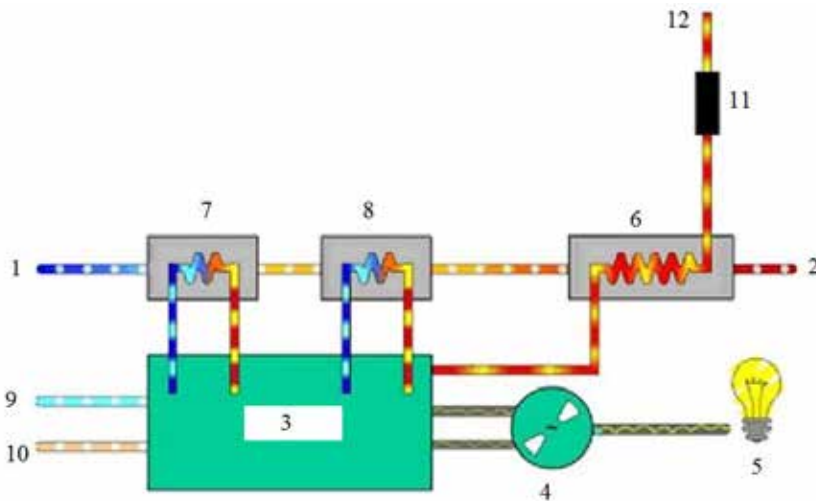

Fig. 7.39. Operation scheme of cogeneration power plant with gas engine: 1 – water from heat networks; 2 – water in heat networks; 3 – ICE; 4 – generator; 5 – electricity for object; 6 – exhaust gas heat exchanger; 7 – oil cooling; 8 – engine cooling; 9 – air; 10 – gas; 11 – exhaust gas suppressor; 12 – in the chimney (Source: WEB-13)

The main advantages of cogeneration power plants comparing with traditional methods of electric energy production:

- Opportunity to produce electricity and heat simultaneously.
- Opportunity to use renewable energy sources.

- Power supply is much more reliable – since there is no dependence from local electricity distribution company moderators.
- Significant fall of CO₂ emissions into the atmosphere. Cogeneration plants, by utilizing commonly wasted heat, reduces CO₂ gas emissions to the atmosphere by 3 times.

However, the production of electricity from conventional renewable energy sources (like solar energy, geothermal energy, etc.) is a much „cleaner” way. However, cogeneration systems are a great and promising alternative, at the same time allowing companies to become less dependent upon local electricity distribution networks. The typical yield of gas engine’s gaseous energy is equal to 42% of the totally energy consumption of the gaseous fuel used. More energy from the engine can be recovered by recovering heat from intercooler, engine cooling contour, lubricating oil cooling water, and also from exhaust gases.

7.8. Fuel cells

A fuel element consists from a conductor (electrolyte) and two electrodes (Fig. 7.40), contacting with an electrolyte.

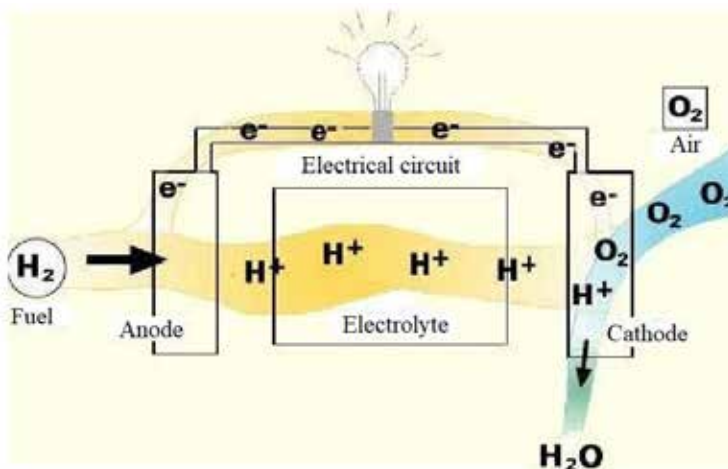

Fig. 7.40. Fuel cell principle (Source: WEB-14)

Fuel and oxygen are continuously supplied to the electrodes – anode and cathode, and the inert components and residues of oxygen are continuously discharged from them. When fuel cell is working, electrolyte and electrodes do not run out and change,

and chemical energy of fuel is directly converted into electric energy. In fuel element, in which pure hydrogen and oxygen are used, anode undergoes hydrogen separation and its ionization. From hydrogen molecule forms two hydrogen ions and two electrons. Hydrogen in the cathode binds to oxygen, which results in the formation of water. The main ecological effect is the release of water vapor into the atmosphere instead of a large amount of carbonic acid, produced by traditional thermal power plants.

The fuel cell – an electrochemical device, that generates electricity using hydrogen and oxygen. It is one of the most promising modern alternative fuel technologies. These fuels operate on a simple basis – combining hydrogen with oxygen in order to produce electricity for powering the electric engine. This engine emits completely harmless products – water vapor and heat, and therefore no harmful substances are released into the environment:

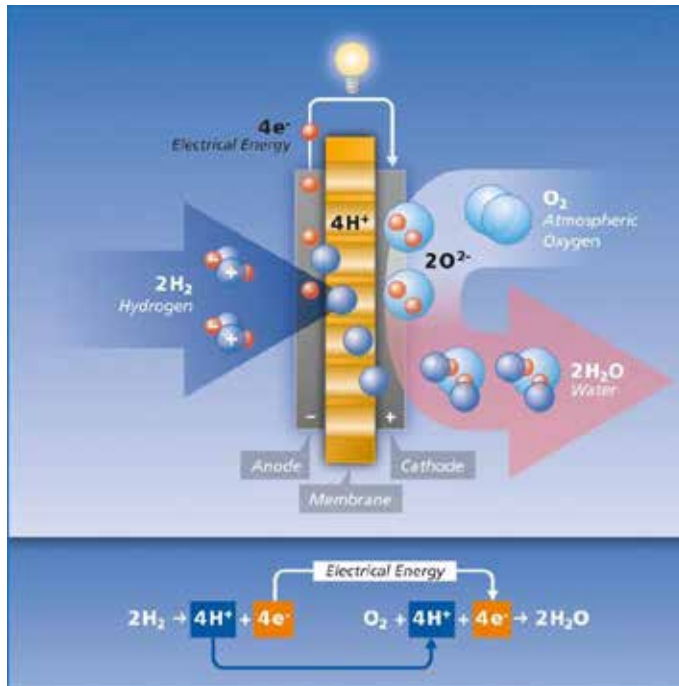

Fig. 7.41. Fuel cell structure (Source: WEB-15)

The fuel cell consists of: anode, cathode and electrolyte filled between these electrodes (Fig. 7.41). The electrolyte is the ion carrier, i.e. the most important layer. The fuel cell content, fuel type and operating temperature depend on the electrolyte. The

PEMFC electrolyte is a denser polymeric membrane that is very conductive for ions and completely impermeable to electrons and gases. This membrane can be made of a pure polymer or a composition of polymers, for example: a sulfonated fluorocarbon polymer. Electrodes (anode and cathode) have high electrical conductivity. Gas-fired electrodes are made of porous. PEM fuel cell is classified as low temperature (operating temperature – 70-90°C). The anode half of the hydrogen gas is transmitted to the protons and electrons by means of a catalyst. The electrons from the outer circuit travel from the anode to the cathode (thereby generating electricity). Meanwhile, hydrogen ions (protons) travel through the polymer membrane to the cathode. The supply of oxygen (from the air) binds to the protons and the excited electrons. The product of this reaction is water and heat. The efficiency of the fuel element reaches 40-50%.

Fuel element consists of a conductor (electrolyte) and two electrodes, contacting with an electrolyte.

According to the used electrolyte and operating temperature, FE is divided into following basic types: alkalines (AFC), proton exchange membranes (PEMFC), direct methanol (DMFC), phosphoric acid (PAFC), melted carbonates (MCFC), solid oxide (SOFC).

References

DIR 2012/27/EU – Directive 2012/27/EU of the European Parliament and of the Council of 25 October 2012 on energy efficiency, amending Directives 2009/125/EC and 2010/30/EU and repealing Directives 2004/8/EC and 2006/32/EC Text with EEA relevance <https://eur-lex.europa.eu/legal-content/en/TXT/?uri=celex%3A32012L0027>

Gyls, J. (2012) *Garų ir dujų turbinų teoriniai pagrindai*. KTU Technologija.

Kilait, L. & Puodžius, R. (2007) Įvairių kogeneracijos technologijų įrengimo galimybių ir sąnaudų bei rekomendacijų dėl šių technologijų diegimo studija parengimas. Ataskaita Nr. 012007. UAB “AF-Enprima” & UAB “Termosistemų projektai”.

Švenčianas, P. & Adomavičius, A. (2011) *Inžinerinė termodinamika*. KTU Technologija.

WEB-1: Educational Technology Clearinghouse. Available from: https://etc.usf.edu/clipart/77700/77750/77750_dl_trbine.htm. [Accessed 25th August 2018].

WEB-2: Woodford Ch., *Explain that Stuff*. Available from: <https://www.explainthatstuff.com/steam-turbines.html> [Accessed 25th August 2018].

WEB-3: <https://www.quora.com/In-impulse-turbine-why-the-enthalpy-drop-takes-place-in-nozzle-itself-why-there-is-no-enthalpy-drop-in-blade-passage-of-turbine-in-steam-power-plant>

WEB-4: <https://www.sandvik.coromant.com>

WEB-5: <https://www.globalsources.com/gsol/I/Steam-turbine/p/sm/1157611943.htm#1157611943>

WEB-6: <https://www.olympus-ims.com/en/applications/wall-thickness-turbine-blades/>

WEB-7: PBS POWER EQUIPMENT. Available from: http://www.pbspe.cz/eng/index.php?action=reference_detail&id=56. [Accessed 25th August 2018].

WEB-8: Available from: <http://www.ipieca.org/resources/energy-efficiency-solutions/power-and-heat-generation/open-cycle-gas-turbines/> [Accessed 25th August 2018].

WEB-9: Available from: http://www.stoomturbine.nl/foto_siemens.html. [Accessed 25th August 2018].

WEB-10: Available from: <https://www.britannica.com/technology/steam-engine>. [Accessed 25th August 2018].

WEB-11: Available from: <https://yachtmoceans.com/mme-microturbines-superyacht-generators/> [Accessed 25th August 2018].

WEB-12: Electronic Journal MOTOPRESS [Online]. Available from: <http://www.motopress.lt/trumpas-susipazinimas-su-keturtafciau-varikliu/>. [Accessed 25th August 2018].

WEB-13: Website of Company GANDRAS [Online]. Available from: <http://gandras.net/en/equipment> [Accessed 25th August 2018].

WEB-14: Image from website of ScriGroup.com [Online]. Available from: <http://www.scrigroup.com/limba/lituaniana> [Accessed 25th August 2018].

WEB-15: Website of Company PROTON MOTOR [Online]. Available form: <http://www.proton-motor.com> [Accessed 25th August 2018].