

# 6. BIOMASS HEAT CENTRES

## 6.1. Technologies for burning biomass

The classification of solid biofuel depends upon the determination of the fuel origin and it is divided into (LST EN 14961-1):

- wood biomass,
- herbaceous biomass,
- fruit biomass,
- biomass mixtures.

Biomass burning is the conversion of accumulated energy. Most part of the energy produced from biomass causes heat, which is gained by burning wood, firewood, wood pellets, wood chips, wood sawdust, etc.

Biofuel is burnt in solid fuel boilers. Their equipment is described below:

1. boiler and furnace,
2. smoke treatment equipment and chimney flue,
3. air supply fan,
4. smoke exhauster,
5. boiler protection measures,
6. fuel warehouse,
7. fuel supply equipment.

The main technological parts of the boiler house are the *boiler* and the *furnace*.

Direct biomass burning or burning with biomass gasification is included in low power boilers. Direct burning boilers can burn various fractions and biomass (granules or briquettes). In these boilers, fuel can automatically be supplied into the furnace and the power of the boiler can be regulated by altering the amount of fuel and air. Boilers with biomass gasification show a higher energy efficiency. The quality of burnt fuel must be substantially higher (maximum humidity 11-14%). Mass is gasified in a separate area of the boiler itself. In small and medium power biomass boilers several types of furnaces can be applied. The hearth furnace is used for burning dry, well-shredded, low-ash biomass in facilities up to 5 MW. Grade furnaces are applied in medium and high power boilers. Grade furnaces are the most versatile constructions for burning biomass and wood waste.

Fuels can be defined as substances which are worthwhile to burn, both from technical and economical perspectives, in order to obtain heat. The most common use of bioenergy is heat production.

The biomass burning process consists of three main phases:

- 1<sup>st</sup> – phase: exothermic – combustion with oxygen (oxidation up to 1300°C);
- 2<sup>nd</sup> – phase: endothermic – material decomposition, gasification and combustion (pyrolysis up to 600°C);
- 3<sup>rd</sup> – phase: biomass drying – water evaporation (up to 150°C).

According to the method employed to supply biomass and its burning conditions, all biomass burning systems are divided into the following categories:

1. Fireguard system;
2. Lower power systems;
3. Supercharged systems;
4. Gasification systems;
5. Fuel systems of “boiling layer”.

The main technological part of the boiler house is a boiler with a *furnace*. Burning processes and construction of the furnace are highly dependent on the fuel characteristics (calorific value, amount of volatile substances, humidity and so on). Three main chemical elements appear in the composition of solid fuel: carbon (C), hydrogen (H) and sulphur (S). Heat is released when they burn.

During chemical reactions, these elements burn completely:



Combustion products are carbon dioxide CO<sub>2</sub>, water vapour H<sub>2</sub>O and sulphur dioxide SO<sub>2</sub>.

### Fuel combustion on the grate

When fuel is burnt on the grate (Fig. 6.1), the following processes take place:

1. Temperature of the fuel layer starts to rise and the drying process starts;
2. When the fuel temperature reaches 100-105°C, volatile substances are separated (primarily hydrocarbons). Then fuel particles become porous;
3. Depending on the type of fuel, it ignites at a temperature of 220-300°C;
4. Carbon combustion ceases at 800-900°C. Ash falls down to the grate.

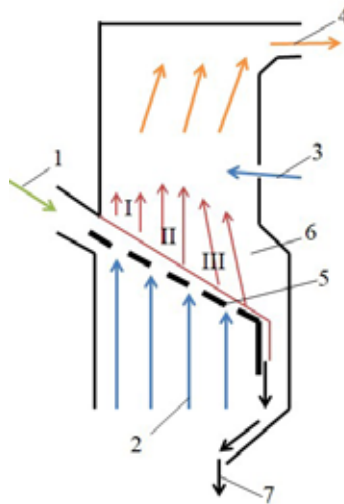

**Fig. 6.1.** Wet fuel's combustion zone on tilted grate: 1 – Biofuel; 2 – Primary air; 3 – Secondary air; 4 – Combustion products; 5 – Grates; 6 – Furnace; 7 – Ashes. I zone – fuel drying; II zone – pyrolysis; III zone – Carbon combustion (Source: own elaboration)

Moving fire grates may be horizontal or inclined at a certain angle. The most common movable inclined fire grades are those which are composed from rows of consistent stationary and non-stationary fire grates (Fig. 6.2). Moving the fire grate makes move back – forth by shifting fuel across fire grates, known as cracked, partitions of the furnace are moved by hydraulic cylinders. Each cylinder can move one or two rows of grids. Depending on the boiler's power, the grids can be moved at a certain distance (for example, 200 mm). This shift of grids results in an uniform displacement of biofuel in grid zones, at different speeds in each grid area (drying of biofuel, gasification, combustion, removal of ashes).

Burning fuel particles mix with fresh fuel particles. Then, the fuel layer, located in the furnace space, renews the fuel's layer uniformly, which disperses according to the length of fire grates.

Grates are divided into separate sections of fire grates, which are numbered. The numbers are necessary because fuel can move at different speeds, which corresponds to the different burning stages: drying, separation of volatile substances and burning of coke residues.

The primary air which is supplied separately under each fire grate section intensifies the combustion of various biomass. Fire grates are cooled down by primary air, which passes by side channels between fire grates. Bark, sawdust, wood chips are used for

wet fuel burning. Water cooled fire grates can be used for dry biofuel or fuel with a low ash melting temperature.

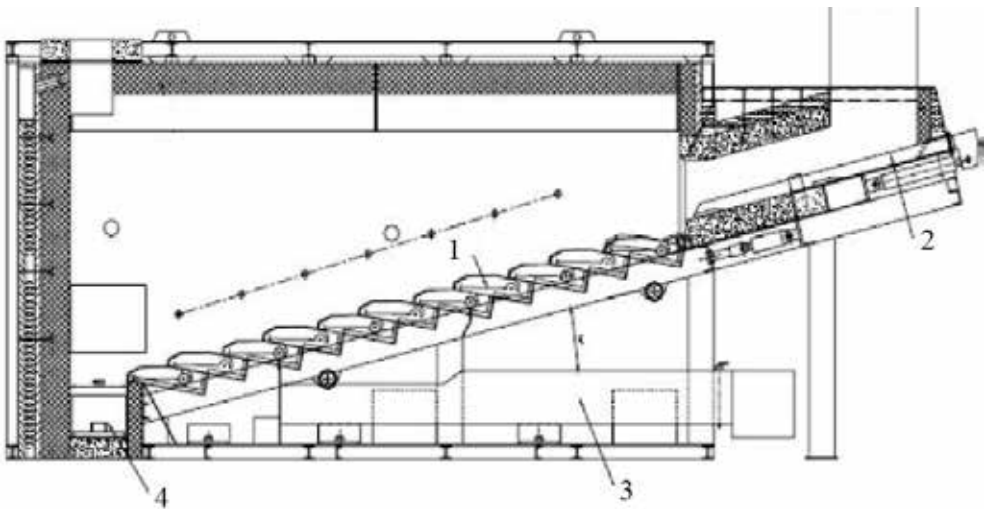

Fig. 6.2. Inclined moving fire grates: 1 – moving fire grates in the furnace; 2 – fuel supply; 3 – air channels; 4 – ash scraper (Source: Buinevičius, 2013)

The furnace with leaning moving grids is shown in Fig. 6.3:

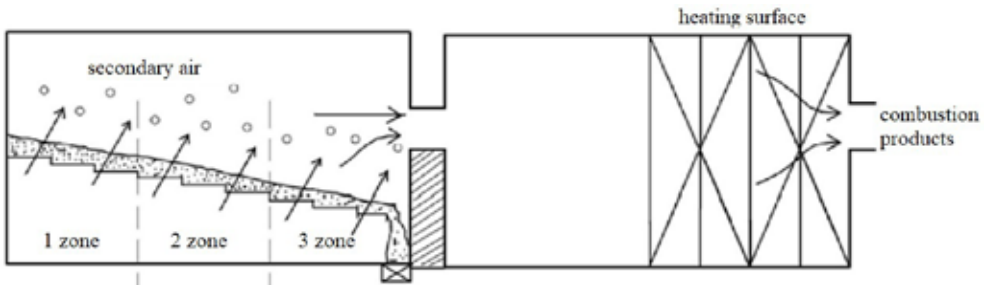

Fig. 6.3. Biofuel burning on leaned moving grids (Source: Buinevičius, 2013)

Primary heated air for biofuel burning is supplied under fire-grate, whereas secondary air – above the fire-grate. Primary air cools down grids. A low-power water heating boiler furnace with moving inclined fire grates is shown in Fig. 6.3.

In a boiler’s furnace, the layer of burnt fuel on grids is controlled by an infrared sensor. The system uses smoke gas recirculation.

Horizontal moving grids are employed for burning fuel in a horizontal layer. The combustion process in a horizontally moving grid is schematically shown in Fig. 6.4:

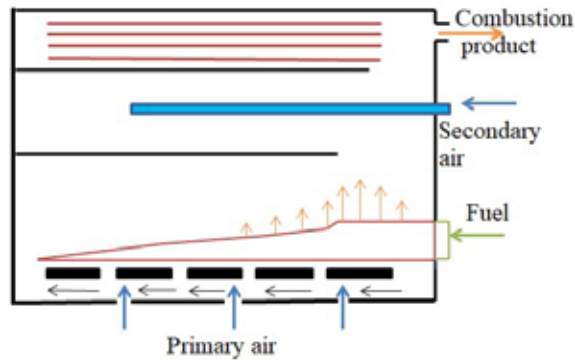

Fig. 6.4. Furnace with horizontal grids (Source: own elaboration)

Zones of fuel combustion (from left to right): drying, separation of volatile substances and burning of coke residue. Fuel movement takes place thanks to special, according to diagonal, positions of the fire grates. The advantage of this technology is the movement of fuel made possible by gravity control. Furthermore, since it is necessary that the pushing force placed on the horizontally moving fire grates is greater than the one on the tilting moving grids, the fuel layer distributes evenly. Thus, the risk of slagging area of higher temperatures is reduced. However, the disadvantage of horizontally moving grids is a higher degree of fuel relegation through fire grates. Consequently, the indicators of reliability for grids are reduced.

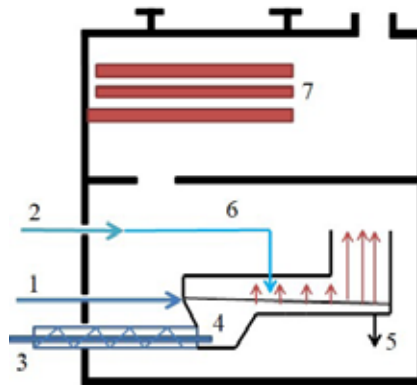

Fig. 6.5. Furnace with lower fuel feed: 1 – primary air; 2 – secondary air; 3 – speech; 4 – lower combustion zone; 5 – ash removal mechanism; 6 – complete combustion chamber; 7 – heat exchanger (Source: own elaboration)

Furnaces with a lower feed of dry biofuel are shown in Fig. 6.5. These furnaces are inexpensive and relatively simple when managing combustion processes for small

fractions of biofuel. This combustion method is used for low power installations (up to 6 MW) in a boiler-house.

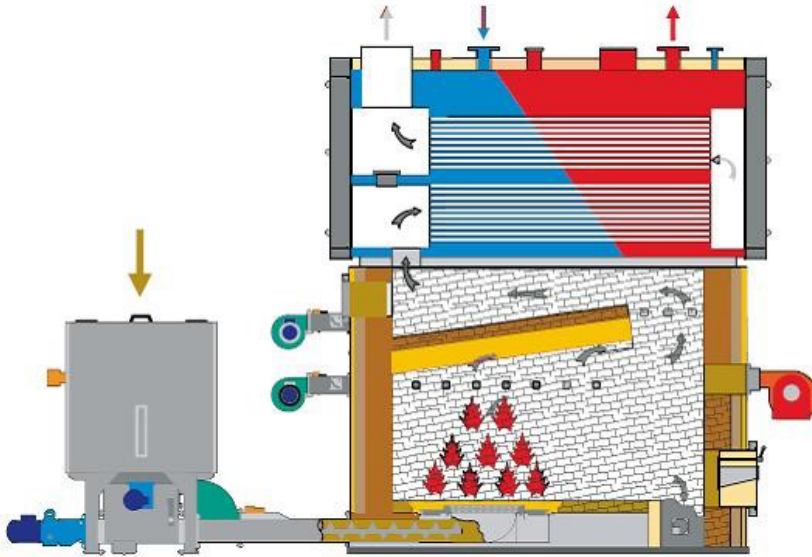

Fig. 6.6. Fuel burning, when humidity up to 50% (Source: WEB-1)

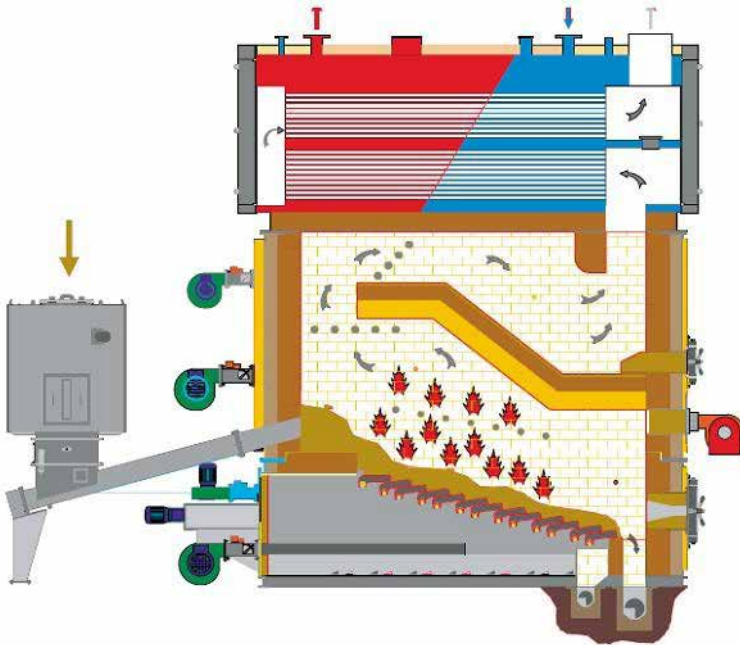

Fig. 6.7. Fuel burning on fire-grade, when humidity up to 120% (Source: WEB-1)

Fuel is transferred to the combustion chamber through the bottom of the spiral conveyor and distributed on the fire-grates. Fire-grates can be flat or within leaning. Primary air supplied under the fire-grates and secondary – above the layer of burning fuel.

The *disadvantage* of these furnaces is the problematic organization of slag and conglomerates (charred logs) disposal, since high ash content biofuel is burnt (bark, straws, crop waste treatment) and there is nowhere to implement them.

The main *advantage* is the simple management and good manoeuvrability of these furnaces, since the weight of the fuel contained in the combustion zone is limited.

In solid fuel boilers *upper combustion systems* (Fig. 6.8) can be used. In traditional boilers, fuel burns from the bottom, all at once, so it burns quickly. In upper combustion boilers burning takes place by the principle of a candle – from top to bottom. The principle of combustion – slow fuel burning from the top down.

An example of upper burning boiler is shown in Fig. 6.8:

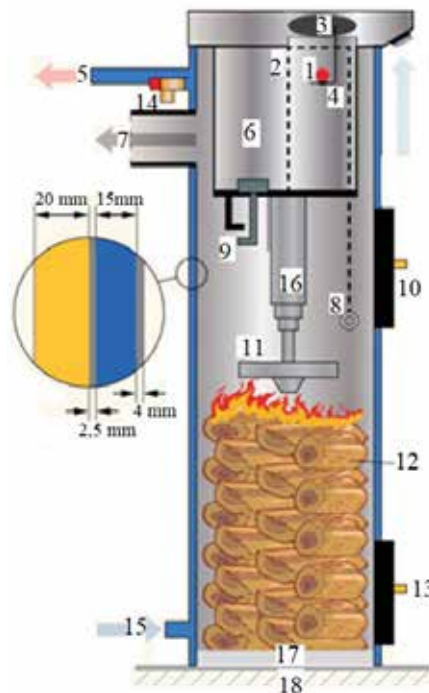

**Fig. 6.8.** The construction of upper burning of the solid fuel boiler: 1 – thermostatic air traction controller; 2 – cable lifting system; 3 – air valve with air intake collector; 4 – regulator's traction leg; 5 – warm water coupling; 6 – air heating chamber; 7 – smoke disposal outlet; 8 – air distribution lifting cord; 9 – barriers (firewood/char coal) switch handle; 10 – fuel loading door; 11 – air distributor; 12 – fuel; 13 – ash removal door; 14 – protective valve; 15 – return water; 16 – air supply pipe (telescopic); 17 – the basis of the boiler; 18 – heat-resistant floors (Source: WEB-2)

Universal solid fuel boiler of lower burning (Fig. 6.9):

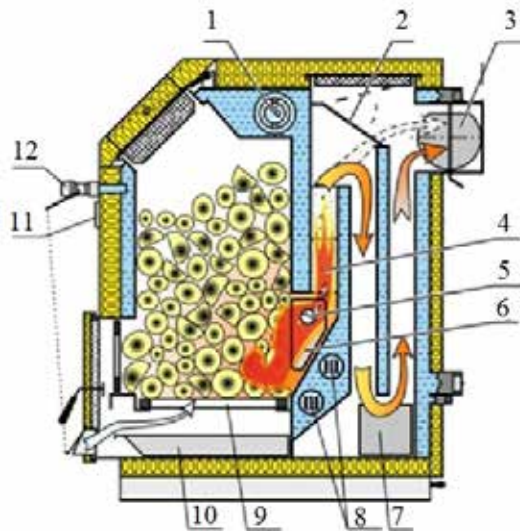

**Fig. 6.9.** Scheme of lower burning of solid fuel boiler: 1 – place for emergency cooling coil-pipe; 2 – shut-off valve; 3 – chimney flue and smoke traction valve; 4 – bricks of the combustion chamber; 5 – secondary air inlet; 6 – cast iron element catalysts; 7 – soot cleaning lids; 8 – place for electric heating elements; 9 – grades; 10 – ash capacity; 11 – thermo manometer; 12 – traction regulator (Source: WEB-2)

An exceptional feature of steel boilers (lower burning) is the falling of colder smoke to the chimney. Therefore, before disposing it, it is converted even several times in the boiler. These boilers also exhibit an extremely high ratio of coefficient efficiency of 82%. They also have a relatively long burning period and the fuel which is employed is universal: firewood, wood waste, coal, coke, sawdust, peat briquettes.

*Gas generational boilers* (Fig. 6.10). The boiler operates on the basis of gas generation: at first, firewoods are ignited in a low-oxygen combustion chamber. Then, the combustion chamber forms flammable, high carbon gas, which enters the furnace, located at the bottom. In this furnace, additional supplied oxygen-gas ignites.

The process of combustion of these boilers is controlled by a computer. Computer-controlled primary and secondary air supply. Gas generating boilers burn up to 12 hours. However, the fuel (wood) must be dry, not more than 20% moisture. The efficiency of gas generating boilers is 94%.

The process of combustion of these boilers is controlled by a computer, which controls the primary and secondary air supply (the supply of air is determined by the continuous measurement of the oxygen content from combustion products). Gas



generational boilers are also characterized by a relatively long combustion (up to 12 hours). But the fuel (wood) must be dry, not less than 20% moisture. The efficiency of gas generating boilers is 94%. Gas generational boilers, compared to classical boilers, use wood energy in a manner which is three times more efficient.



**Fig. 6.10.** Steel gas generational boiler Caldera Megatherm: 1 – control panel; 2 – start trigger lever; 3 – fuel chamber (furnace); 4 – control levers for primary and secondary air flows; 5 – burner (aerator); 6 – ash collector; 7 – combustion chamber; 8 – shut-off valve; 9 – smoke extraction fan; 10 – flame – gas flow direction of furnace; 11 – water supply to the system; 12 – cooling coil; 13 – connecting the cooling coil (Source: WEB-3)

Granulated biofuel combustion technological scheme is shown in Fig. 6.10: from the capacity of pellets through the helical conveyor, pellets are supplied to the boiler furnace, in which the combustion takes place. Formed high temperature smoke gas (combustion products) falls into mid-pipe space. Heated water flows inside the pipes and hot smoke gas goes around tubes, by giving back heat to water. By giving back heat to water, smoke gases cool down and flow down into the cyclone, in which, smokes are cleared from mechanical impurities (ash particles). Ashes from cyclone fall away into the ash container and clean smoke is pushed into the chimney by exhauster (traction fan).

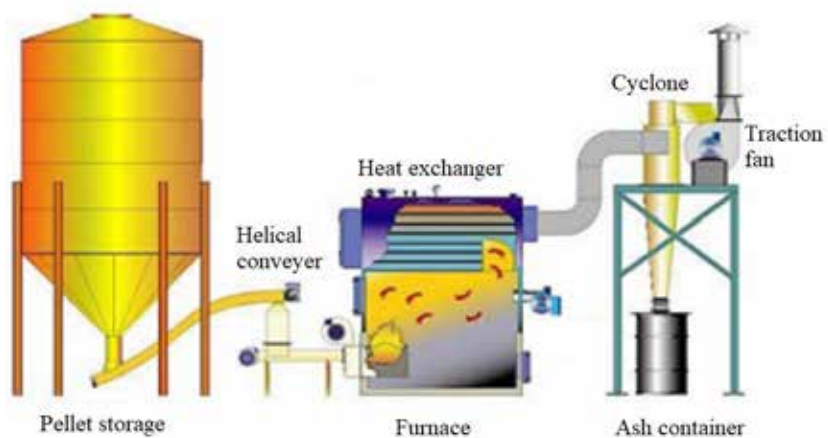

Fig. 6.11. Granulated biofuel combustion line (Source: WEB-4)

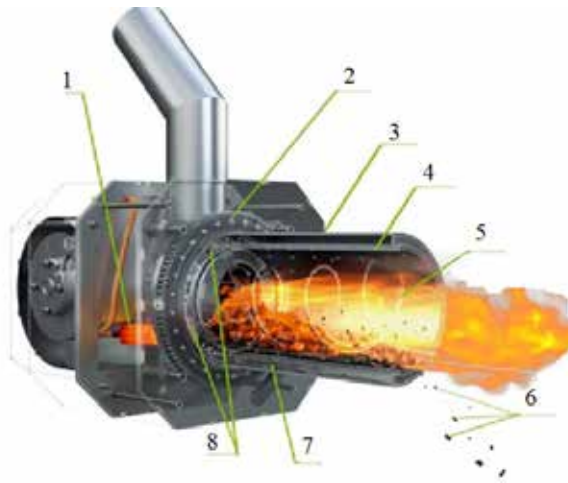

Fig. 6.12. Pellet burning (Source: WEB-5)



Fig. 6.13. Pellet boiler (Source: WEB-6)

Pellet boiler and burner are shown in Figs. 6.13 and 6.14:



**Fig. 6.14.** Pellet burner: 1 – place of ignition; 2 – rotation mechanism; 3 – rotating air chamber; 4 – rotating combustion chamber; 5 – rotating flame effect; 6 – ash and slag disposal; 7 – ash removal from the chamber; 8 – air distribution (for primary and secondary fuel combustion) (Source: WEB-7)

The burning technology of the solid fuel in a boiling layer at atmospheric pressure is shown in Fig. 6.15.

If grids are installed in any of the furnace chambers (a), on which biofuel is supplied by a layer and a small amount of air under grids is given, soon after heating of initial layer, the fuel combustion starts by releasing volatile combustion materials from the surface. A fixed burning layer will hold on grids and combustion of fuel will take place in the layer. By increasing the air flow through the grating, the fuel particles will operate at a speed pressure. This pressure must overcome the weight of the particles.

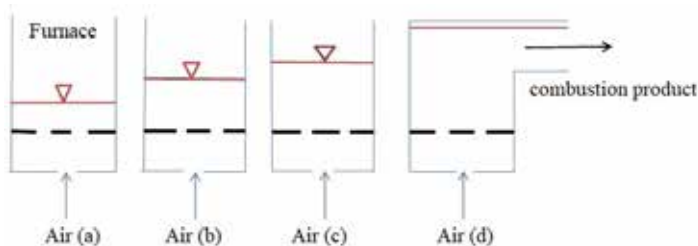

**Fig. 6.15.** The change of boiling layer at different amounts of air flow combustion (Source: own elaboration)

For a certain air flow rate, fuel particles in updraft will occur in a hovering position and in thickness the burning layer will increase (b).

By further increasing the flow rate of air, separate air bubbles appear in a layer (c), and the layer of fuel thickness will increase even more. This phenomenon is known as the *bubbling boiling layer*. This layer is very similar to water boiling state and, as a matter of fact, the fuel combustion method is called the “boiling” layer. By increasing the air flow rate of air even more, the lifting force, acting on fuel particles will be so high that these particles will not be able to burn and will escape from the boiling layer. By increasing the amount of air flow furthermore, the visible layer fades away. Thus, the burning of accumulated fuel particles takes place throughout the whole space of the furnace combustion chamber, by intensely mixing among themselves (d). Larger amounts of fuel particles fail to burn in furnace space and they leave the chamber before entering the cyclone – which is a cylindrical device where unburnt solid particles are affected by the centrifugal forces by separating them from the smoke. The products of combustion are redirected to a second section of the boiler – the convectional funnel – for water heating or steam overheating, whereas, unburnt fuel particles from the cyclone are returned to the combustion chamber. So this is a circulating boiling layer. Its main advantage is that the circulating material exceeds the amount of supplied air for combustion hundreds of times.

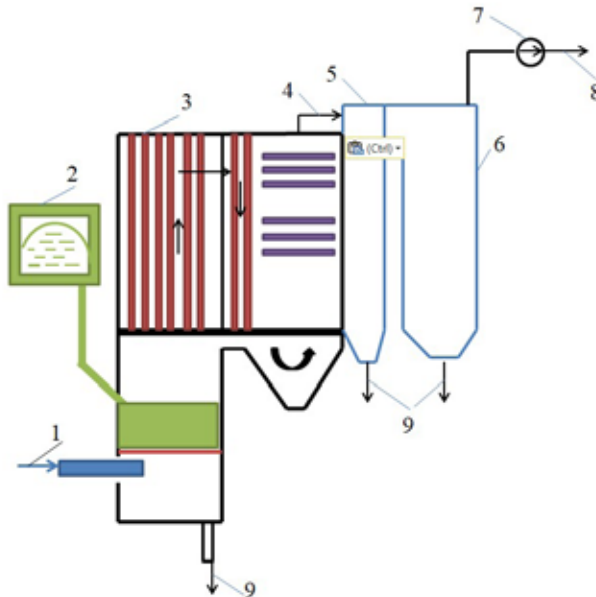

**Fig. 6.16.** Scheme of biofuel's boiler house: 1 – Air; 2 – Container of biofuel; 3 – Boiler; 4 – Combustion product; 5 – Cyclone; 6 – Multicyclone; 7 – Exhauster; 8 – To the chimney; 9 – ashes (Source: own elaboration)

The boiler burns low calorific wood fuel of 50-60% moisture (Fig. 6.16). The Boiler house scheme – a cyclonic type, tiled with fire-resistant ceramic material; this ensures high degree of fuel combustion (combustion efficiency of boiler can reach 92%).

In cyclonic-type harness rotating air flow, fuel particles are thrown off to the interior of the furnace walls.

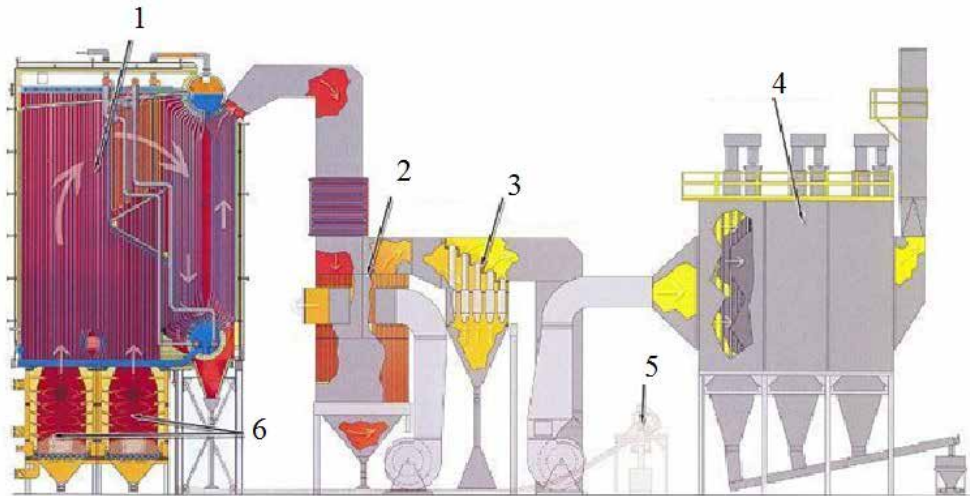

Fig. 6.17. Scheme of the boiler fueled by biomass: 1 – double drum steam heater 2 – air heater; 3 – multi-cyclone; 4 – electrostatic precipitator; 5 – ash conveyor; 6 – furnace (Source: WEB-1)

In this furnace it is possible to burn high fractions of fuel (up to 75 mm). The advantage of cyclonic combustion is the increased burning of fuel.

## 6.2. Gasification and technologies of biomass

*Biogas* – a unique mixture, which is formed from a variety of methods by easily decomposing organic materials. Depending on the raw material, the output of biogas and energy properties can vary greatly. Animal manure, manure, green biomass, sewers and alike can be used for their production. For biogas generation, special equipment is required and due to investment and operational costs, they are far more expensive than natural gas. Typically produced biogas consists of a mixture: methane (40-75%), carbon dioxide (25-50%), nitrogen (6-7%), oxygen, hydrogen, hydrogen sulphide, ammonium compounds, water vapour and other compounds (up to 2%). Calorific capacity of biogas contains about 60% of the thermal value

of natural gas, namely about 6 kWh/m<sup>3</sup>. In order to supply biogas by conventional pipelines of natural gas, they require additional processing; bringing chemical and physical characteristics closer to the characteristics of natural gas. For this purpose, additional equipment needs to be equipped, which removes gas ballast, sulphur compounds, and concentration of methane is increased, etc. *Gasification of biomass* – thermochemical conversion technology. According to the nature of used materials for biomass oxidation for conversion, technologies are divided into:

Gasification in the air, when for oxidation atmospheric air is used;

1. Gasification in pure oxygen;
2. Gasification in steam.

Gasification occurs in 4 stages:

I stage: *drying*

II stage: *oxidation (burning)*, given by Eqs. (6.1) and (6.2).

III stage: *distillation (pyrolysis)*



IV stage: *reduction (decomposition of heavy molecules of biomass – gasification)*



Oxidation reactions (6.1) and (6.2) are exothermic (heat is isolated during the process). Carbon and hydrogen (in this phase they oxidize) are the molecules of organic biomass. They are transformed into carbon dioxide and water vapour. During burning, ashes fall down as mineral components of biomass. During the pyrolysis, a small quantity of resin separates. During the third phase, heavy molecules of biomass, exposed to high temperature, break down to lighter organic molecules and carbon monoxide.

Using air as oxidant, the final product is obtained:

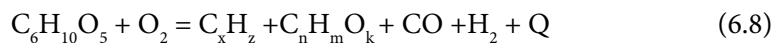

Eq. (6.8) shows that gasification is the process of burning at conditions of reduced air (oxygen) supply. The main product of gasification is flammable gas, which consists of a mixture of carbon monoxide, carbon dioxide, hydrogen, methane, water vapour and nitrogen.

According to the thermal value (MJ/Nm<sup>3</sup>) biogas is distributed into:

1. Low calorific value < 8;
2. Medium calorific value 8-14;

3. Normal calorific value 14-20;
4. High calorific value >20.

*Gasification of biomass* – thermochemical process, during which the portion of organic material of biomass is transformed into flammable gaseous products:

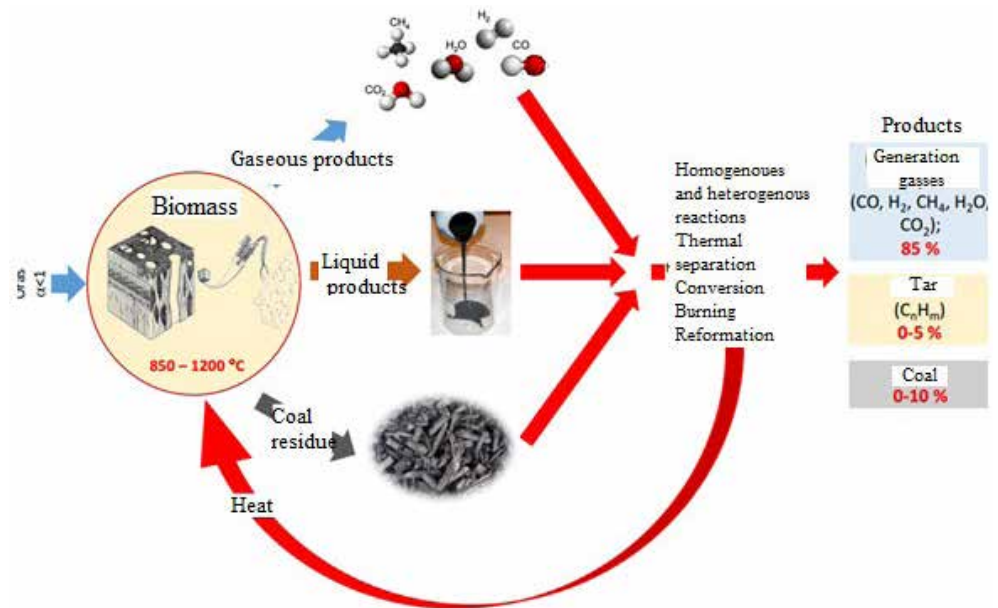

Fig. 6.18. Schemes of gasification cycles (Source: Striugas, 2014)

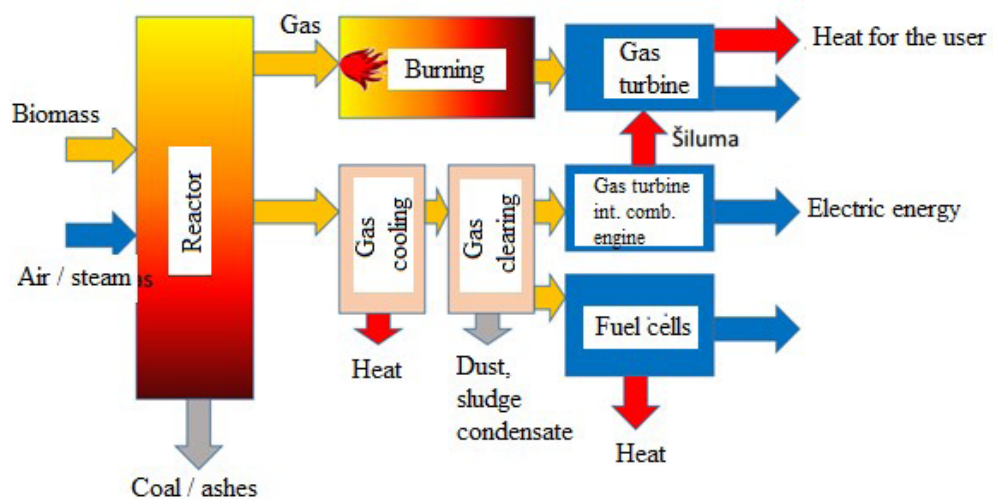

Fig. 6.19. Scheme of gasification cycle (Source: Striugas, 2014)

There are six main areas for exploitation of biological raw materials and waste potential. Biomass gasification is one of the cheapest and environmentally safest ways to get thermal and electric energy. There are two direct ways of obtaining gas from biomass – microbiological and thermal. Wood contains little water and biodegrades very slowly. Therefore, the most effective way of gasification is thermal (pyrolysis) gasification.

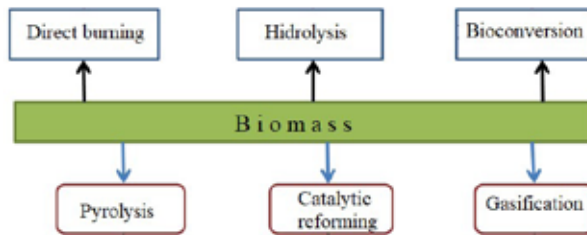

Fig. 6.20. The usage of biological materials and waste potential (Source: own elaboration)

Gasification usually takes place when wood is burning in the open air, forming water vapour and  $\text{CO}_2$  forms, by separating sufficiently enough large quantity of heat to warm up, for example, everyone seating around a camp fire. If obtained water and  $\text{CO}_2$  are placed in the charcoal burning area (obtained from the burning wood), where temperature may exceed  $1500^\circ\text{C}$ , water will separate hydrogen and  $\text{CO}_2$  will be converted into  $\text{CO}$  (a process known as reduction). The result of this process is gas containing 20% of  $\text{CO}$  + little methane and 60% of the ballast material. This gas mixture cleaned and cooled down to less than  $100^\circ\text{C}$ , octane number of 118, burns adequately in internal combustion engines (ICE).

*Pyrolysis* (in greek. Pyr – fire, Lysis – decomposition) is an organic thermal compound of decomposition process subjected to high temperature. The simplest example of pyrolysis is the natural burning of materials (wood, coal, peats, etc.) in the camp fire, in case of fire or in the furnace. Sometimes dry distillation is called pyrolysis. Pyrolysis is one of the most important chemical processes used both in the energetic industry and in other industries, such as metallurgy or oil industry. For example, using the pyrolysis method materials such as charcoal, coke, ethylene, propylene, benzoyl and others are obtained. In industry, pyrolysis is applied to oil, peats, wood, agricultural waste and household waste.

**Pyrolysis:** biomass + temperature = charcoal flammable gas;

**Gasification:** biomass + limited amount of air = gases, flammable gases;

**Ignition:** biomass + sufficient amount of air = combustion products.

Pyrolysis occurs differently, depending on the process conditions (type of raw material, its fraction size, temperature, pressure, oxygen, water, etc.) and design of



the reactor. Thermal decomposition of complex biological organic compounds starts at around 100°C. During the pyrolysis, decomposition of basic wood-based materials starts at about 200°C. Nonetheless, the most important processes occur at even higher temperatures, that is at 1300-1800°C.

The composition of wood contains 45-60% cellulose, 15-35% lignin and 15-25% hemicellulose, as well as tar, tannins, pigments and minerals materials. In the composition of dry wood material, there is about 50% carbon, 6% hydrogen, 44% oxygen, about 0.2% of nitrogen and no more than 1% sulphur. Wood ash melting temperature is 1400°C.

During the pyrolysis of wood's char, from 8-12 m<sup>3</sup> wood useful yield is approximately up to 1 tonne of charcoal. Energy, separated during pyrolysis, is used for further occurrence of this process. In contrast, with the gasification of the biomass, most portion of raw material changes into high-calorie combustible gas, which is used to produce electric energy (approximately 1000 kWh from 1.4 to 1.8 tons of raw material).

### Obtaining Gas in generators. The production of electric energy.

Not only pyrolysis occurs in gas generators; more precisely a process called partial (i.e. incomplete) carbon oxidation. In gas generator (Fig. 6.21) raw material passes through four stages until it converts into gas:

*Stage I* – rapid drying of material subjected to high temperature;

*Stage II* – thermal decomposition of biomass (pyrolysis) by formatting coal and tar, which later evaporates and the result is resin gas;

*Stage III* – the combustion of resin gas and carbon organic compounds;

*Stage IV* – CO<sub>2</sub> conversion to carbon monoxide CO on heated up surface of carbon and water H<sub>2</sub>O – into hydrogen H<sub>2</sub>.

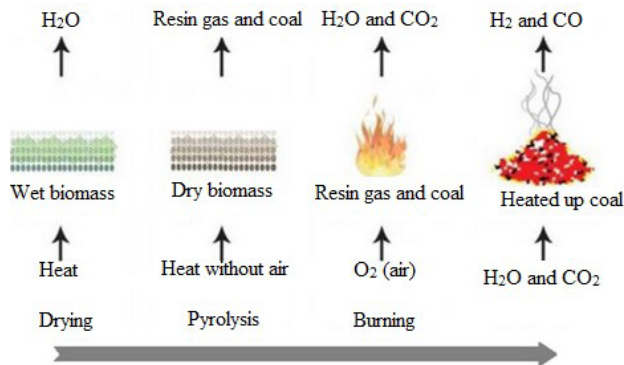
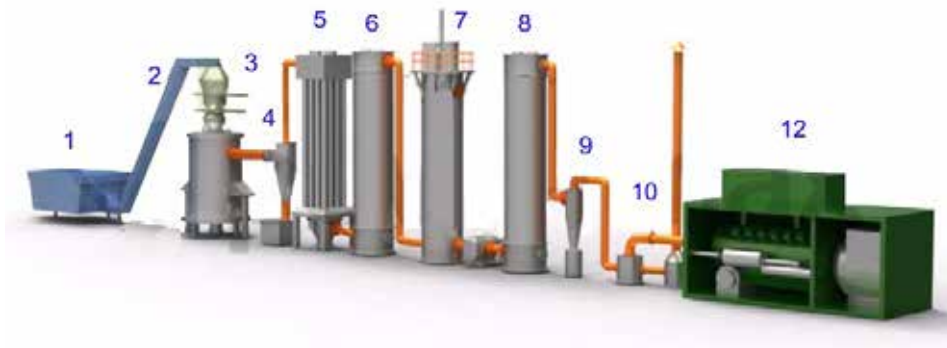

Fig. 6.21. Biomass conversion into gas (Source: WEB-8)

The greater part of the reactions which take place in the gas generators are exothermic. That is to say, they occur by releasing energy.

The main chemical components involved in biomass conversion into gas are carbon, air oxygen and water. Oxidising agents are oxygen, carbon dioxide and water vapour. Direct gasification product of solid bodies always includes a certain amount of  $\text{CO}_2$ , water vapour, methane and the higher hydrocarbons; and by using air – also  $\text{NO}_2$ . Gasification rate is highly dependent on temperature. As pressure increases, the concentration of  $\text{CH}_4$  is also increased. The composition of incoming gas is dependent upon schematic use of the gas generator and schedule of the process. Outgoing gas from the generator is high temperature and has a large amount of impurities (ash and tar). Consequently, the gas generation equipment is supplied together with special cooling and cleaning systems.

Re-processed raw material 1, from the top is loaded into reactor of gasifier 3 (Fig. 6.22).



**Fig. 6.22.** Biomass gasification unit: 1 – biomass container; 2 – supply conveyor; 3 – gasifier; 4 – gas purification cyclone; 5 – gas cooler; 6 – gas cooler; 7 – heat exchanger; 8 – gas cooler; 9 – drier; 10 – buffer tank; 11 – gas burner; 12 – gas generator (Source: WEB-9)

Air and water vapour are supplied from the bottom. The temperature of the upper layer is about  $100\text{--}200^\circ\text{C}$ , gas dries waste materials, entering the reactor; below there is a zone, where pyrolysis processes and organic materials release are predominant. In the middle part of the reactor there is a gasification zone, where coke reaction with oxygen occurs at temperatures  $100\text{--}1200^\circ\text{C}$ , water vapour and carbon dioxide; resulting in occurrence of  $\text{CO}_2$  and  $\text{H}_2$ , a certain part of carbon burns completely;  $\text{CO}_2$  is formed, and due to this fact, a required temperature is maintained throughout the gasification zone.

Throughout the height of the gasifier there are several zones of temperatures. In oxygen free environment, thermal decomposition and coking of organic matter occurs. Gases are enriched by volatile materials during pyrolysis.

In a zone below, in which solid residue consisting of mineral compounds gradually cools down in the environment of gasification flow, enriched with oxygen. In here, the residues of organic compounds and carbon finish burning. Combustible materials are completely transformed into ashes. The lower part of the reactor is the zone where solid residues (which is up to 100°C) cools down totally and ash residue is removed. The ushering of generation gases is located in the upper part of the reactor.

Further gas is cleaned, cooled down and supplied to the generator devices or boiler.

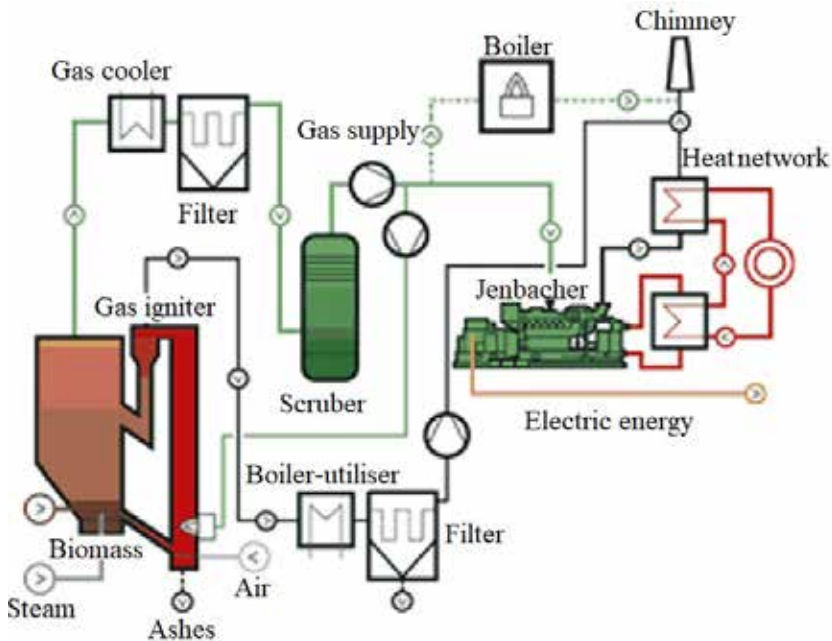

Fig. 6.23. Wood gasification technology (Source: WEB-10)

Fig. 6.23 shows a diagram of biomass plant gasification in Austria: the gasifier and building of engine hall with a gas piston engines GE Jenbacher. This plant produces 4.5 MW of thermal energy for district heating and 2 MW capacity of power plant from recyclable 1760/h wood waste.

The main installation of the facility is the gasifier of „boiling” layer. Supplying steam during gasification, biomass is heated up to 850°C. The usage of steam instead of air allows to eliminate impurities of nitrogen and resin in the pyrolysis gases, and

a relatively high calorific capacity is obtained. The remaining carbon particles enter the combustion chamber through the boiling layer; thus additional heat is obtained. The obtained gas is separated and cooled down by giving up heat to a heat supply system.

Gas is cleaned from dust in the fabric filters, then further in scrubbers' gas is additionally cleared from tar, ammonia and acidic components. The gas composition:  $H_2$  – 40%;  $CO$  – 24%;  $CH_4$  – 10%;  $CO_2$  – 23%;  $N_2$  – 3% gas calorific value 2615 kcal/nm<sup>3</sup> (10956,85 kJ/nm<sup>3</sup>).



Fig. 6.24. Boiling layer gasifier for wood waste (Austria) (Source: WEB-11)

High temperature of exhaust gases can be repeatedly re-used in a boiler-utilizer for production of steam and hot water (Fig. 6.24): worked off high temperature generator gases are supplied to the boiler-utilizer, in which water is heated and evaporated. Produced overheated steam is supplied to a steam turbine, which is connected by a single shaft to an electric generator. Steam, when in contact with the turbine blades, rotates the turbine's impellers, thereby also rotating the shaft of an electric generator. Steam from the turbine's intermediate discharge degree is supplied to the network's preheaters, from which cooled water of heating network is heated up to necessary temperature and returned into outdoor heating networks. This power plant (Fig. 6.25) is called *cogeneration*, because in the single heat source there are two types of energy produced: *thermal energy* in the form of DH and *electric energy*.

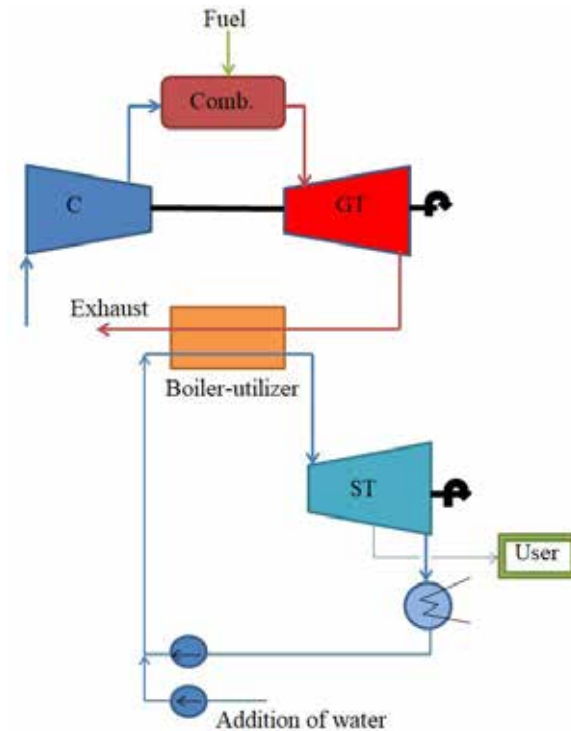

Fig. 6.25. Cogeneration unit with heat recovery system (Source: own elaboration)

On November 2016 there are 2529 power plants installed in Lithuania, which have licenses for production of electric energy from renewable energy sources. The total installed cumulative power capacity reaches – 787.951 MW:

- Solar power plants – 72.28 MW (2231 units);
- Wind power plants (parks) – 493.781 MW (150 units);
- Power plants of solid biomass – 59.96 MW (11 units);
- Power plants of biogas – 34.021 MW (38 units);
- Power stations of hydroenergy – 127.909 MW (99 units).

## 6.3. Biogas. Production of biogas

### 6.3.1. Composition and properties of biogas

Biogas is formed by decomposing any organic material in the environment. Biogas zero oxygen is a unique mixture according to the composition of gaseous components,

which is formed as a result of the final waste of organic part for anaerobic microbial fermentation or chemical reactions between the decomposed parts of wastes.

The main components of biogas are methane (CH<sub>4</sub>) and carbon dioxide (CO<sub>2</sub>). In biogas, depending on the composition of raw material, there are very small amounts of hydrogen (H<sub>2</sub>) hydrogen sulfide (H<sub>2</sub>S), nitrogen (N) and other materials. Mostly in biogas methane ranges from 55 to 70%, carbon dioxide – from 30 to 45% hydrogen – up to 1% and sulphide up to 3%.

Since biogas is a mixture of methane and carbon dioxide, their flammability concentration limits are slightly different from pure methane and depend on the concentration of the latter in the biogas. Gas ignition concentration limits in the air is a very important indicator. It means when the temperature of gas and air mixture reaches the ignition temperature, if gas concentration in the mixture is between lower and upper concentration limits, the mixture will burn (if the volume of the mixture is sufficiently large – it'll explode).

The most important property of biogas – the concentration of methane in biogas is determined by *thermal value, ignition temperature and concentration limits in air*.

### 6.3.2. Materials for production of biogas

Biogas production is a complex biological-chemical process in which organic materials are exposed to different types of bacteria. During this process, complex organic compounds are decomposed into elements, which methanogenic bacteria convert into biogas – combination of methane, carbon dioxide and other gases. Methanogenic bacteria are very sensitive anaerobes. Therefore, temperature, acidity and alkalinity, oxidation reduction potential and other environmental factors must meet certain specific requirements. Metabolic activity and the intensity of methane production also depend on the composition of the processed substrate, supported by temperature and its fluctuations, retention time and inhibiting factors. Microbiological activity in the biogas reactors is most favourable at neutral or slightly alkaline conditions (6,0 < pH <8,5).

In energy of biogas it is accepted to divide process temperatures into three groups: psychrophilic (10-25°C), mesophilic (25-42°C) and thermophilic (52-56°C).

The main raw material for the production of biogas are organic wastes of various origins. Some wastes are difficult to be decomposed and less biogas is obtained from them, in others – higher amount of biogas with a higher methane content can easily be obtained from them.

For production of biogas, organic wastes are used, which are obtained from agriculture, cattle breeding, from municipal wastes in urban parts, from urban water treatment plants sludge and technological waste of food processing industry.

### **Usage of Sludge**

The most popular common uses of sewage sludge are: sludge composting and biogas extraction. These are the main and most widely used methods. Sludge is an organic material, which separates heat during burning. Sludge can be burned separately or in combination with another fuel, such as municipal or industrial waste. In the latter case, a proper incinerator is required with the modern smoke treatment equipment. As the energy demand grows more and more, an alternative source is the burning of sludge. This sludge utilization method is already presented as most progressive. One more step towards progressiveness is the fact that, from 2014 sludge can no longer be transported to landfills. Data from previous years in the EU countries indicates that most of the sludge was used in agriculture. In 2010, in Europe 46% sewage sludge was used in agriculture, 21% thrown into landfills, 20% burned down, 7% used for compost production, 6% – for other uses (data provided by the Ministry of Environment).

In the Netherlands, in some regions of Belgium, Austria, Switzerland, the use of sludge in agriculture was effectively banned, due to the possible negative influence of potentially toxic substances, both to the human health and the environment.

European practice shows that the most rational use for treatment plants sludge is to use soil for fertilization or for production of biofuel – granules or biogas.

The main elements of a system (Fig. 6.26) are a belt drying unit, a small gas turbine and burning furnace with grade fordried sludge.

EU Directive 86/278 encourages to use sludge in agriculture, in an effort to avoid its harmful effects on soil, vegetation, wildlife and human health. The amount and composition of biogas are highly dependent on the composition of the substrate.

Organic matter is placed in sealed containers, where during the anaerobic digestion process of the bacteria (usually 65% methane and 35% CO<sub>2</sub>) biogas is produced.

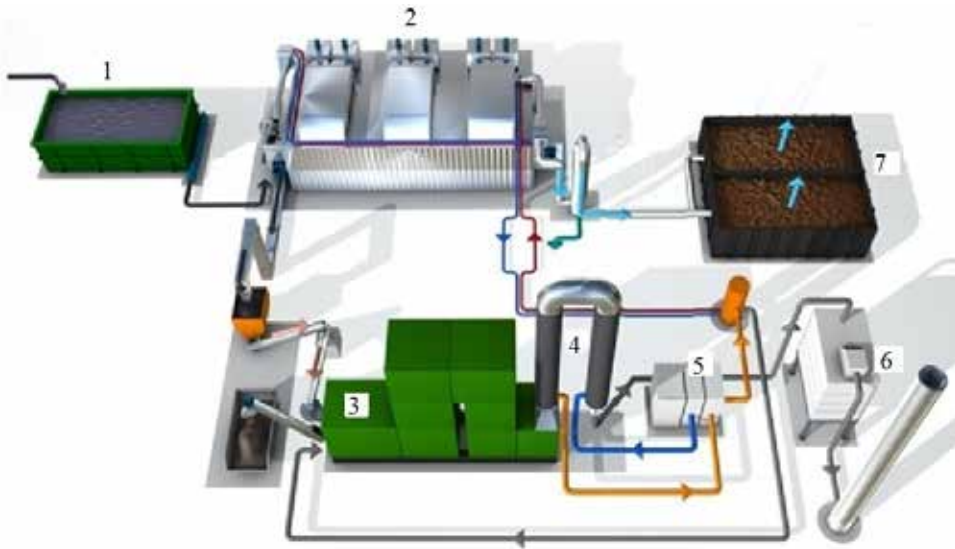

Fig. 6.26. Principal scheme for Straubing FVC equipment: 1 – sludge feeding; 2 – sludge dryer; 3 – sludge burning equipment; 4 – heat exchangers; 5 – gas turbine – electric generator; 6 – air cleaning after burning; 7 – air drying after dryer (Source: WEB-12)

Agriculture wastes are transported into special reservoir. Wastes are sorted out and crushed. These kind of wastes are supplied to the reactor. To accelerate decay process in the reactor, steam is supplied. Wastes are heated up to 36°C–56°C. Composed biogas in the reactor are supplied into cogeneration units. Wet residue is aerated, humidity is removed and placed into composting container.

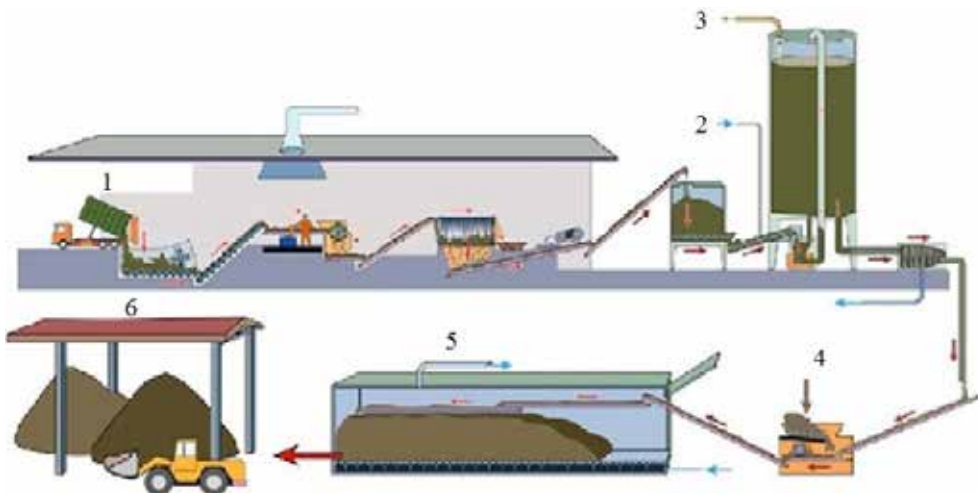

Fig. 6.27. The production of biomass in agriculture: 1 – waste delivery; 2 – supplied heat (steam); 3 – agriculture biomass; 4 – moisture removal; 5 – composting; 6 – treated waste (Source: WEB-13)



Produce biogas are cleansed in special units, cleansed biogas are compressed in the compressor. High pressure biogas are supplied to the steam boiler (to produce steam) and to the Internal combustion Engine - to produce thermal and electrical energy.

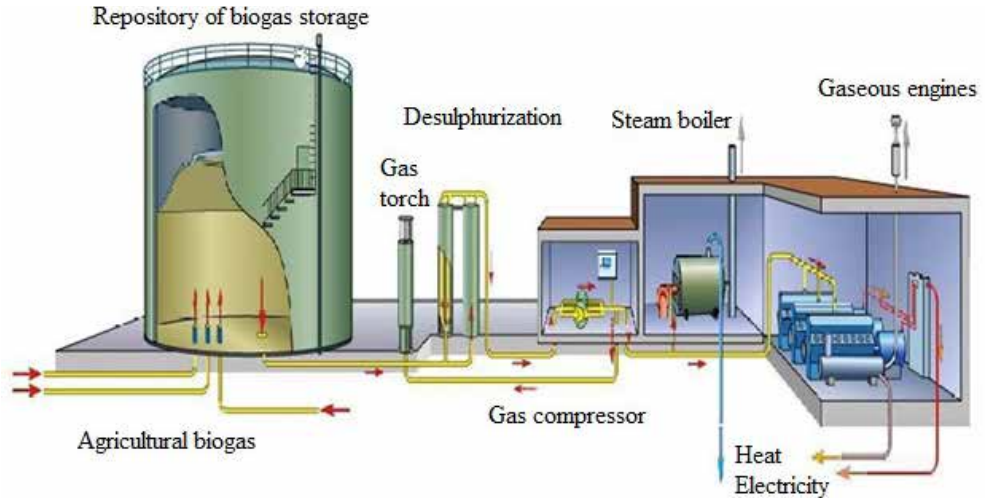

Fig. 6.28. Usage of biogas (Source: WEB-13)

The yield of biogas and composition are highly dependent upon the composition of substrate.

### Bioreactor

The *Bioreactor* is a device for the production of biogas by decomposing organic materials bacteriologically under anaerobic conditions. In the bioreactor most favourable conditions for microbial activity are formed. By increasing the temperature of substrate, the rate of biogas decomposition increases and reaches maximum value at  $t \approx 35-38^{\circ}\text{C}$ . By further increasing the temperature of substrate, the formation rate of biogas slightly decreases and later it begins to increase and reaches second maximum value at  $t \approx 52-60^{\circ}\text{C}$ . If temperature continued to increase, yield of biogas would go down until it would stop entirely, because an excessively high temperature would kill bacteria.  $t \approx 35-38^{\circ}\text{C}$  is the most favourable conditions for one kind of methanogenic bacteria to multiply, which numbers increase rapidly, and they are able to produce more biogas. By raising the temperature, conditions for these bacteria deteriorate, their reproduction decreases along with a reduction in the amount of produced biogas. However, when the temperature reaches the interval of  $50-60^{\circ}\text{C}$ , optimal conditions for other methanogenic species of bacteria form and they begin to multiply rapidly and a larger amount of bacteria produce more biogas. Effectively operating bioreactor must have:

- hermetically sealed corps,
- an efficient heating system,
- good thermo-insulation of the corps,
- substrate mixing system, which would maintain homogeneous temperature of the substrate,
- loading and unloading system of a substrate.

Figure 6.29 shows a schema of biogas technology stages.

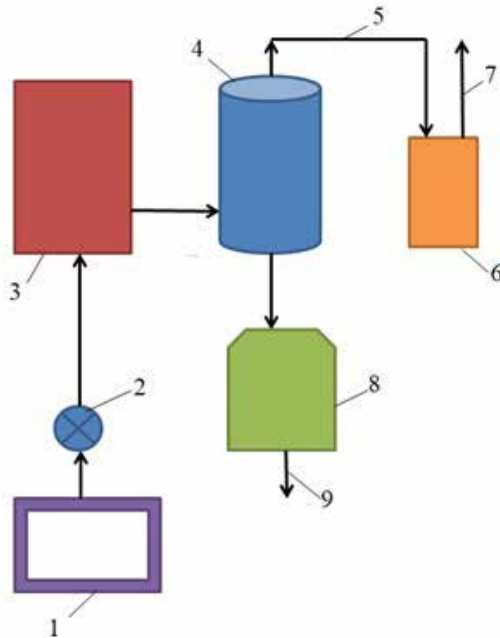
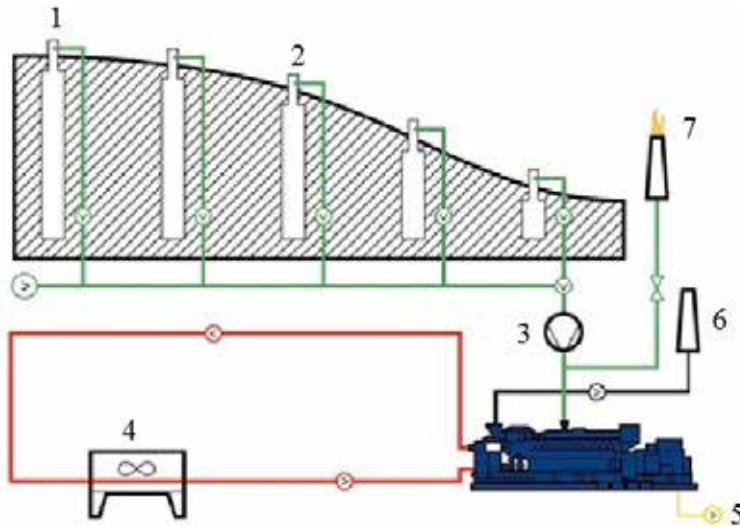

**Fig. 6.29.** Biogas technology stages: 1 – Substrate storage; 2 – Mixer; 3 – Reactor; 4 – Reservoir (biogas storage); 5 – Biogas; 6 – Power supply; 7 – Energy (Source: own elaboration)

## Landfill gas

Due to the natural biodegradation of organic materials in the landfills, high amounts of methane and  $\text{CO}_2$  are formed. When these gases are not collected and used, they are released into the atmosphere (as gases), which cause a greenhouse effect. The capacity of heating gas exceeds 20 times that of carbon dioxide, thereby further contributing to the global warming.

The waste landfill is a natural biogas generator. In the landfill microorganisms are exposed to organic residues. Biogas contains 40-60% of methane and other part is carbon dioxide. Other chemical compounds make up a very small percentage. Methane and carbon dioxide are greenhouse gases (Fig. 6.30).



**Fig. 6.30.** Scheme of a typical usage of landfill gas: 1 – landfill; 2 – gas bore; 3 – gas compressor; 4 – external cooler; 5 – electric power; 6 – exhaust emissions from the engine; 7 – gas torch (Source: WEB-13)

The proper usage of recycled waste is a great source of renewable energy.

Production rate of landfill gas and the total amount depends on many factors (WEB-14). The main ones are: composition of wastes; pre-treatment of secondary waste recycling degree: (there is amount of waste, suitable for secondary recycling) waste age; the thickness of waste layer and density of the landfill; the size of the landfill and waste content in it; the conditions of climatic and environmental, etc.

*Landfill gas* is collected from the waste centres using gas collection systems. About 50% of these gases consist of methane ( $\text{CH}_4$ ) and other 50% – Carbon dioxide ( $\text{CO}_2$ ). The composition of landfill gas may contain a small amount of non-methane organic compounds.

The usage of landfill gas can be very different. It depends on the degree of purified gas. There are three levels of gas purge.

Minimally purified landfill gas can be directly burnt in boilers, brick kilns, dryer furnaces, heating devices of greenhouses. Medium purified landfill gases can be used for heat production, by burning them in boilers, furnaces; for production of electricity and heat, by burning them in gaseous internal combustion engines, turbines or cogeneration plants.

*High degree purity* gas or pure methane can be supplied into the network of natural gas. From an economic point of view, the most effective way to use the landfill gas is direct burning.

### **Power plant of biogas**

Biogas plant structure and technological scheme depends on various factors: from composition and type of the material, its method of delivery, type and size of bioreactors, process parameters, use of recycled substrate, composition and quantity of produced biogas, type and quantity of energy conversion equipment, produced by energy consumers. Classical biogas plants are equipped with raw material collection, preparation and transportation equipment, bioreactors, produced biogas storages, treatment and incineration equipment, tanks of recycled biomass, separators, process equipment controllers and data loggers, electrical and thermal energy networks and distribution devices.

Biogas plant consists of the following main components:

- transportation, storage, pre-treatment of biomass and feed into apparatus of bioreactors;
- bioreactor;
- storage and handling facilities of degassed substrate;
- the equipment of biogas storage, cleaning and further use.

Depending on the type of biomass it may be necessary to sort raw material, crush, heat up to higher temperature in order to kill disease-carrying microorganisms, or otherwise processed. A degassed solution of biomass can be used in agriculture as liquid fertilizer or as a raw material for the production of dry fertilizer. In the beginning, produced biogas are accumulated in gasholder, whose purpose is to level up the differences between their production and usage.

Biogas can be used in three different ways:

- without additional purification burned in furnaces of boilers;
- with a minimal cleaning, by removing moisture and hydrogen sulphide, are burnt in cogeneration devices (usually in internal piston combustion engines);
- purified to pure methane and supplied to the grid of natural gas.

The main product of biogas plants – biogas is used for electricity and thermal energy production (Fig. 6.31).

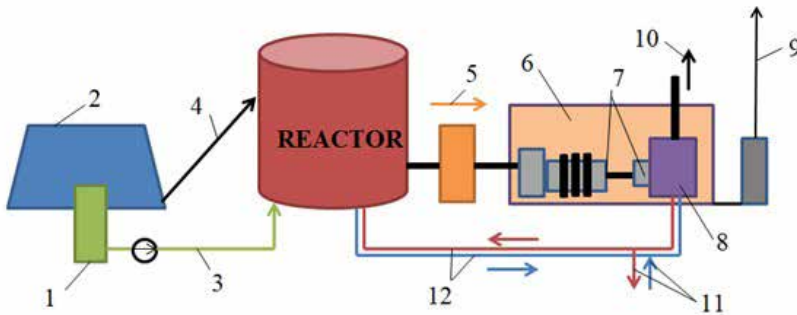
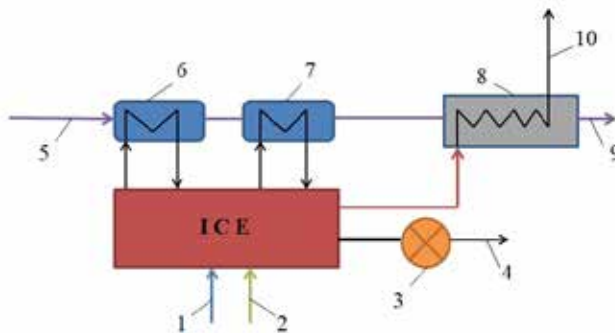

**Fig. 6.31.** Scheme for biogas usage in cogeneration: 1 – Liquid feedstock capacity; 2 – The farm; 3 – Liquid raw material; 4 – Supply of solid raw materials; 5 – Biogas; 6 – Cogeneration unit; 7 – Generator; 8 – Heat exchanger; 9 – Transformer; 10 – Exhaust gas; 11 – Heat technology, for heating; 12 – Warning the reactor with warm water (Source: own elaboration)

Biogas facility does not produce thermal energy directly, but on the contrary, it uses this energy. Biogas installations operating at a temperature (mesophilic) reaches 37-38°C; the same device is going exothermic and endothermic chemical reaction. Heating the substrate in the reactor is necessary to allow for material degradation. Biogas, which is distinguished by the anaerobic (without oxygen) decomposition, contains about 2/3 of methane, so the first biogas application – is the burning of thermal energy. Burning takes place in conventional gas boilers or burners, which are used for natural gas. The biogas is about 55-75% methane ( $\text{CH}_4$ ) and it is the energy release from the combustion of biogas, in proportion to the amount of methane in the biogas. Thermal energy per unit of biogas will need 1.5 times more than the gas.

Another way is to produce heat energy from cogeneration. Cogeneration facilities – are where burning biogas (and not only) at the same time there are two forms of energy and thermal energy. Cogeneration units can be reciprocating and gas turbine (Fig. 6.32). In the first case – a classic internal combustion engine (ICE), working in the oil and biogas mixture.

Thermal energy from the cogeneration facility with hot water (about 75°C) circulating therein cogenerator heat exchanger warming extract.



**Fig. 6.32.** Cogeneration power plant with internal combustion engine: 1 – Air; 2 – Gas; 3 – Generator; 4 – Electricity to the consumer; 5 – Water from the consumer; 6 – Oil cooling; 7 – Engine cooling; 8 – Heat utilization of combustion products in the exchanger; 9 – Hot water for the consumer; 10 – to the chimney (Source: own elaboration)

The heat exchanger heated by the heat exchange medium which cools down the engine system is the crankcase oil or exhaust gases. In the ICE the lubrication oils, cooling water and exhaust gases are used up to heat water from the user. In combustion engines (ICE) for igniting the fuel chemical energy is converted into thermal energy.

The efficiency of the plants which runs ICE are up to 90%; electricity produced – 35% heat – 65%. The most common type of thermal power plant block with ICE, which is connected to an electric generator. The generator, as a rule, has a constant rotation speed of 1500 rev/min. so as to coincide with the main frequency. Electricity in energy generated by combustion of the biogas can be used for electrical equipment drives, for example: pumps, control systems and stirrers. Before the supply of the thermal power plant biogas, they must be removed of moisture and dried. Most gas engines have strict requirements, limiting sulphur hydrogen, hydrocarbons contained in biogas. Biogas facility energy and cost effectiveness is affected by the heat generated by utilization. Some of the heat employed for heating the reactor (technological heat), and the rest, about 2/3 of the total energy produced – external needs. The heat can be used in industrial processes, agricultural production or buildings.

## References

Buinevičius, K. (2013) *Biokuro katilai šilumos gamybai*. [Online] Available from: [http://www.lsta.lt/files/seminarai/131212\\_AVGO/Buinevicius\\_Biokuro%20katilai%20C5%A1ilumos%20gamybai.pdf](http://www.lsta.lt/files/seminarai/131212_AVGO/Buinevicius_Biokuro%20katilai%20C5%A1ilumos%20gamybai.pdf) [Accessed 10<sup>th</sup> August 2018].

Dzenajavičienė, E. F., Pedišius, N. & Škėma, R. (2011) *Darni bioenergetika*. Kaunas, Lietuvos energetikos institutas.

EU Directive 86/278 Council Directive 86/278/EEC of 12 June 1986 on the protection of the environment, and in particular of the soil, when sewage sludge is used in agriculture <https://eur-lex.europa.eu/legal-content/EN/TXT/?uri=CELEX%3A31986L0278> [Accessed 10th August 2018].

Jakštas, A. (2011) Biomasės panaudojimo galimybės energijos gamybai CŠT sektoriuje. In: *Seminaras Biomasės panaudojimas CŠT sektoriuje esama situacija ir kliūtys jos plėtrai*, 5<sup>th</sup> December 2011, Vilnius. AEBIOM & LITBIOMA.

Kilait, L. & Puodžius, R. (2007) *Įvairių kogeneracijos technologijų įrengimo galimybių ir sąnaudų bei rekomendacijų dėl šių technologijų diegimo studija parengimas*. Ataskaita Nr. 012007. UAB “AF-Enprima” & UAB “Termosistemų projektai”.

Kytra, S. (2006) *Atsinaujinantys energijos šaltiniai*. Kaunas, Technologija.

LST EN 14961-1. Solid biofuels. Fuel specifications and classes. Part 1: General requirements Available. <https://e-seimas.lrs.lt/rs/legalact/TAD/TAIS.456530>

Šalčiūnaitė, B. & Pliopaitė-Bataitienė, I. (2015) Forecast of biogas generation in Lithuanian regional land fills / Lietuvos regioniniuose sąvartynuose susidarancio biodujų kiekio prognozė, *Mokslas – Lietuvos ateitis / Science – Future of Lithuania*. [Online] 7(4), 392-398. Available from: <http://dx.doi.org/10.3846/mla.2015.807> [Accessed 10<sup>th</sup> August 2018].

Striūgas, N. (2014) *Pažangios termocheminės technologijos energijos gamybai iš biomasės* Tarptautinė biomasės energetikos konferencija, 2014. Available from: [http://biokuras.lt/uploads/new\\_assigned\\_files/5.%20Nerijus%20Striugas.%20Sekcija%20B.pdf](http://biokuras.lt/uploads/new_assigned_files/5.%20Nerijus%20Striugas.%20Sekcija%20B.pdf) [Accessed 10<sup>th</sup> August 2018].

Vares, V., Kask, Ü., Muiste, P., Tõnu, P. & Soosaar, S. (2007). *Biokuro naudotojo žinynas*. Vilnius, Žara.

Vrubliauskas, S. (2001) *Sąvartynų dujos ir jų naudojimas*. Lietuvos energetikos institutas.

WEB-1: Website of Company GANDRAS [Online]. Available from: <http://gandras.net/en/equipment> [Accessed 25<sup>th</sup> August 2018].

WEB-2: Website of Company KALVIS [Online]. Available from: <http://www.kalvis.lt/produktai/media/wysiwyg/Skrajuotes/LT/Kalvis> [Accessed 25<sup>th</sup> August 2018].

WEB-3: <https://www.e-ciupk.lt/caldera-kieto-kuro-duju-generacinis-katilas-mega-therm-mt25> [Accessed 17<sup>th</sup> October 2018].

WEB-4: [file:///D:/Documents/Downloads/A.%20Gulbinas%20Biokuro%20gamyba%20\(3\).pdf](file:///D:/Documents/Downloads/A.%20Gulbinas%20Biokuro%20gamyba%20(3).pdf) [Accessed 17<sup>th</sup> October 2018].

WEB-5: Website of Company ENERGIJOSPARKAS [Online]. Available from: <http://energijosparkas.lt/granuliniai-sildymo-katilai/finstar-pro> [Accessed 25<sup>th</sup> August 2018].

WEB-6: Website of Company AUSTROBALTIKA [Online]. Available from: <http://austrobaltika.com/pel-tec-pellet-boilers/> [Accessed 25<sup>th</sup> August 2018].

WEB-7: Website of Company PROTINGA ŠILUMA [Online]. Available from: <http://www.protingasiluma.lt/index.php/granuliu-degikliai> [Accessed 25<sup>th</sup> August 2018].

WEB-8: Website of Company INFINITE ENERGY PVT LTD [Online]. Available from: <http://www.infiniteenergyindia.com/biomass-gasifiers.html> [Accessed 25<sup>th</sup> August 2018].

WEB-9: Website of Company WUXI TENENG POWER MACHINERY CO., LTD. [Online]. Available from: <http://www.wxteneng.com> [Accessed 25<sup>th</sup> August 2018].

WEB-10: [http://www.igreenbuild.com/\\_coreModules/content/contentDisplay.aspx?contentID=266](http://www.igreenbuild.com/_coreModules/content/contentDisplay.aspx?contentID=266) [Accessed 25<sup>th</sup> August 2018].

WEB-11: Website of Energy innovation Austria [On line]. Available from: <http://www.energy-innovation-austria.at/article/forschungsstandort-guessing/>. [Accessed 25<sup>th</sup> August 2018].

WEB-12: Website of AGROZINIUS.LT [On line]. Available from: <http://www.agrozinius.lt/portal/categories/186/1/0/1/article/11593/ar-isnaudosime-energetini-nuoteku-dumblo-potenc>. [Accessed 25<sup>th</sup> August 2018].

WEB-13: <http://www.envija.lt/naujienos/kogeneracijos-panaudojimas-zemes-ukyje/> [Accessed 25<sup>th</sup> August 2018].

WEB-14: Poremo (2018) Biodujos ir gamybos technologija [Online] Available from: <http://www.poremo.com/LT/63/Biodujos-ir-gamybos-technologija.htm> [Accessed 10<sup>th</sup> August 2018].